

BCB 503: RevBayes Intro



Last session: Joint Analysis

Orlando Schwery, 26. Oct. 2021, University of Idaho

A quick recap...

- Let's see what we've done so far
- **24. Aug.:** Intro [Graphical Models & Rev Lang.]
- **31. Aug.:** Trait Evolution [Simple Brownian Motion & OU]
- **07. Sep.:** Biogeography [Simple DEC]
- **14. Sep.:** Diversification [BD, BiSSE, MuSSE]
- **12. Oct.:** Div. Add-On [CID-2, HiSSE]
- **19. Oct.:** Tree-Building & -Dating [Substitution- & Clock-Models]
- **26. Oct.:** Joint Analyses [Mix & Match]

Graphical Models

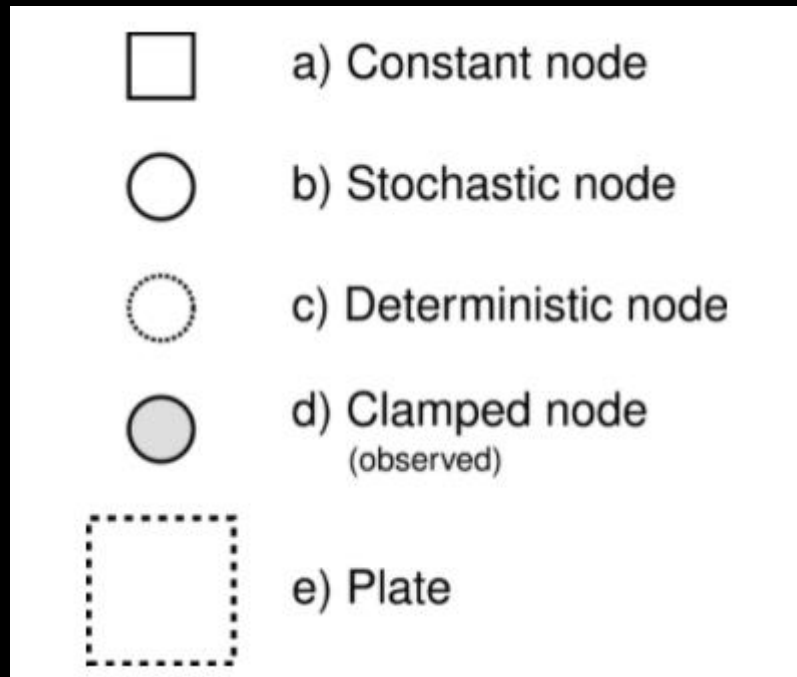

Directed Acyclic Graph (DAG)

→ Nodes (vertices) and Edges (circles/squares and arrows)

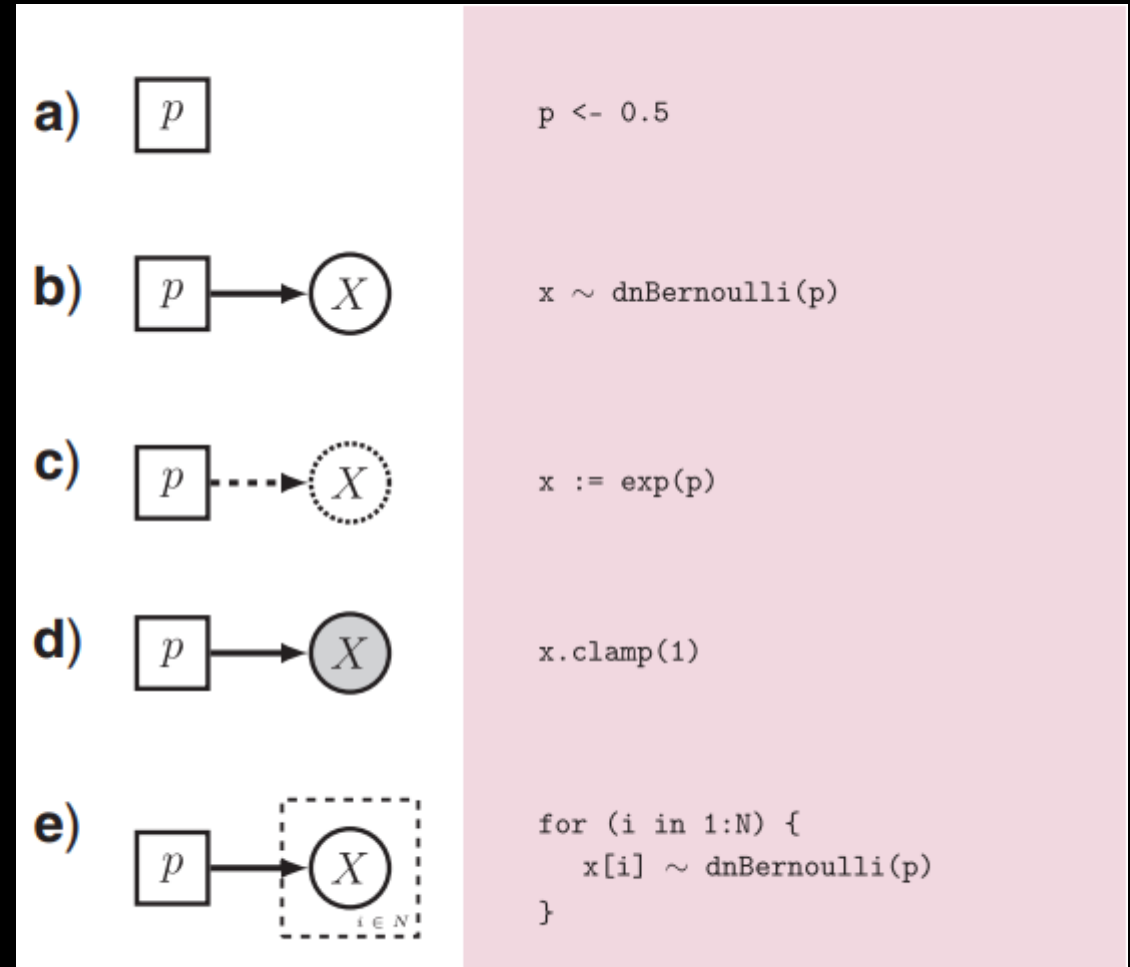

Graphical Models

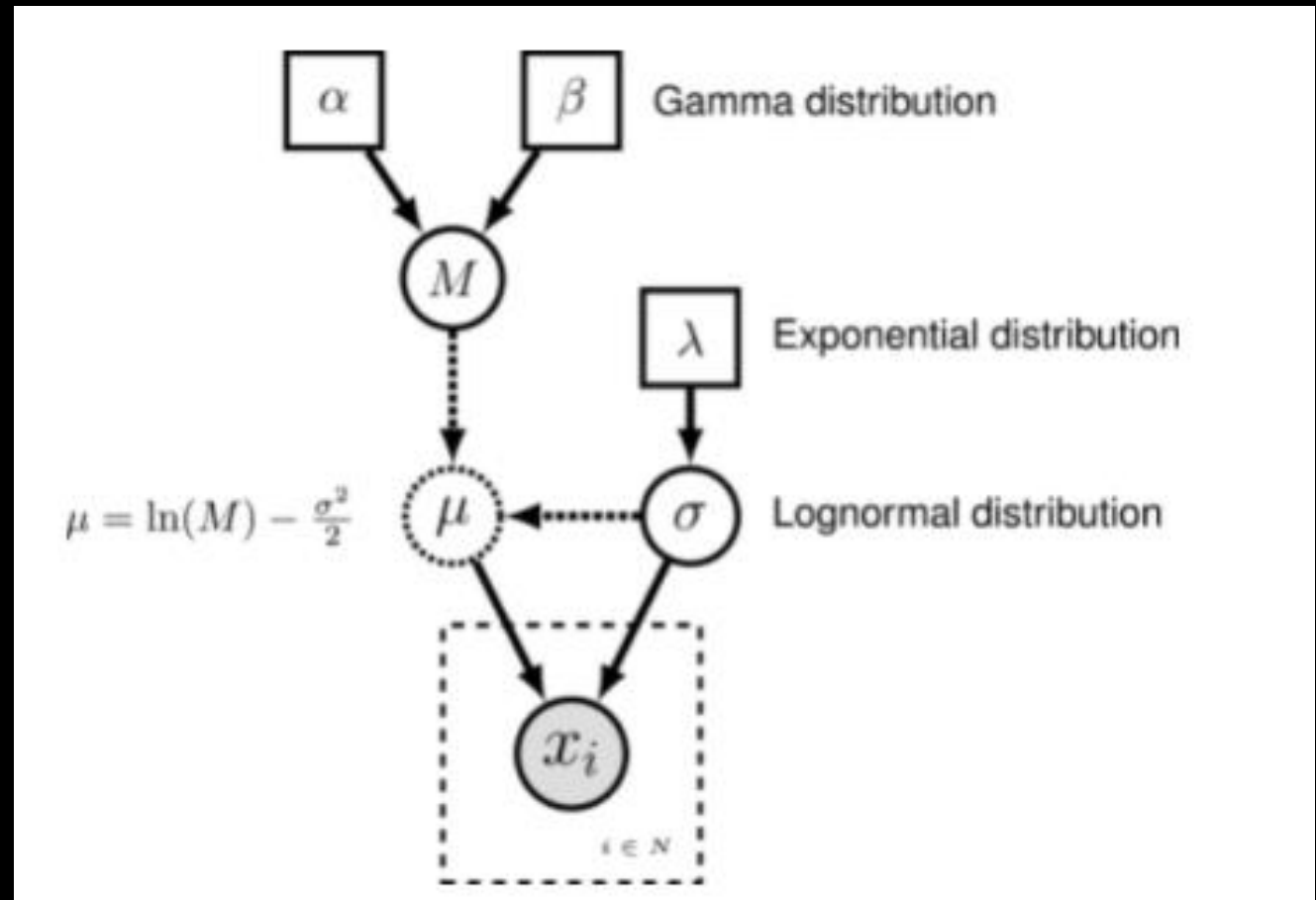
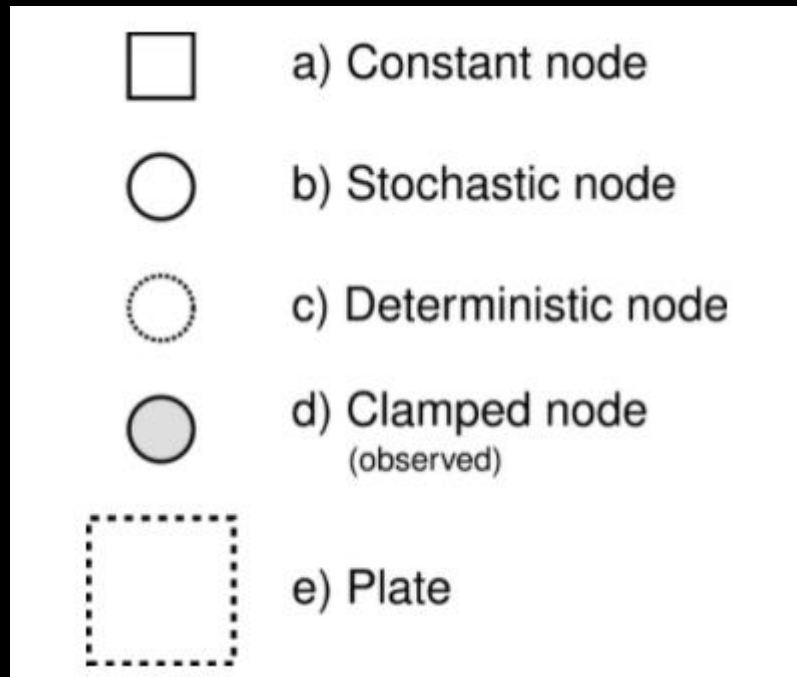

Lognormal Model/Distribution:

$$X = e^{\mu + \sigma z} \quad [\mu: \text{location parameter (log mean)}; \sigma: \text{standard deviation}]$$

Trait Evolution: Simple Brownian-Motion

- Single rate parameter σ^2
 - Drawn from loguniform distribution
 - Lower bound L
 - Upper bound U
- The phylogeny is assumed to be fixed, thus added as a constant node
- The node X contains the BM model for trait data based on tree and rate, with observed data clamped to it

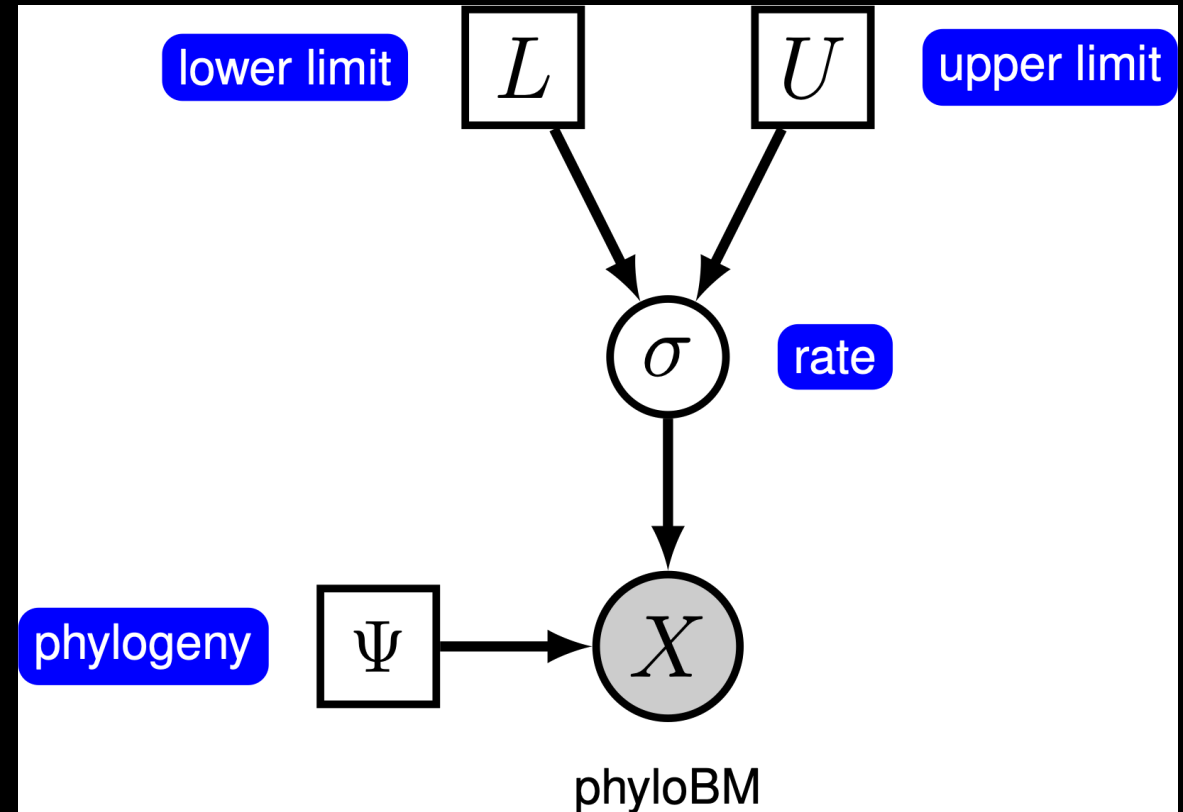

Trait Evolution: Ornstein-Uhlenbeck Model

Trait Strength Optimum Rate

$$dX_{(t)} = \alpha (\theta - X_{(t)}) dt + \sigma dB_{(t)}$$

Change in Trait Change towards Optimum Brownian Motion

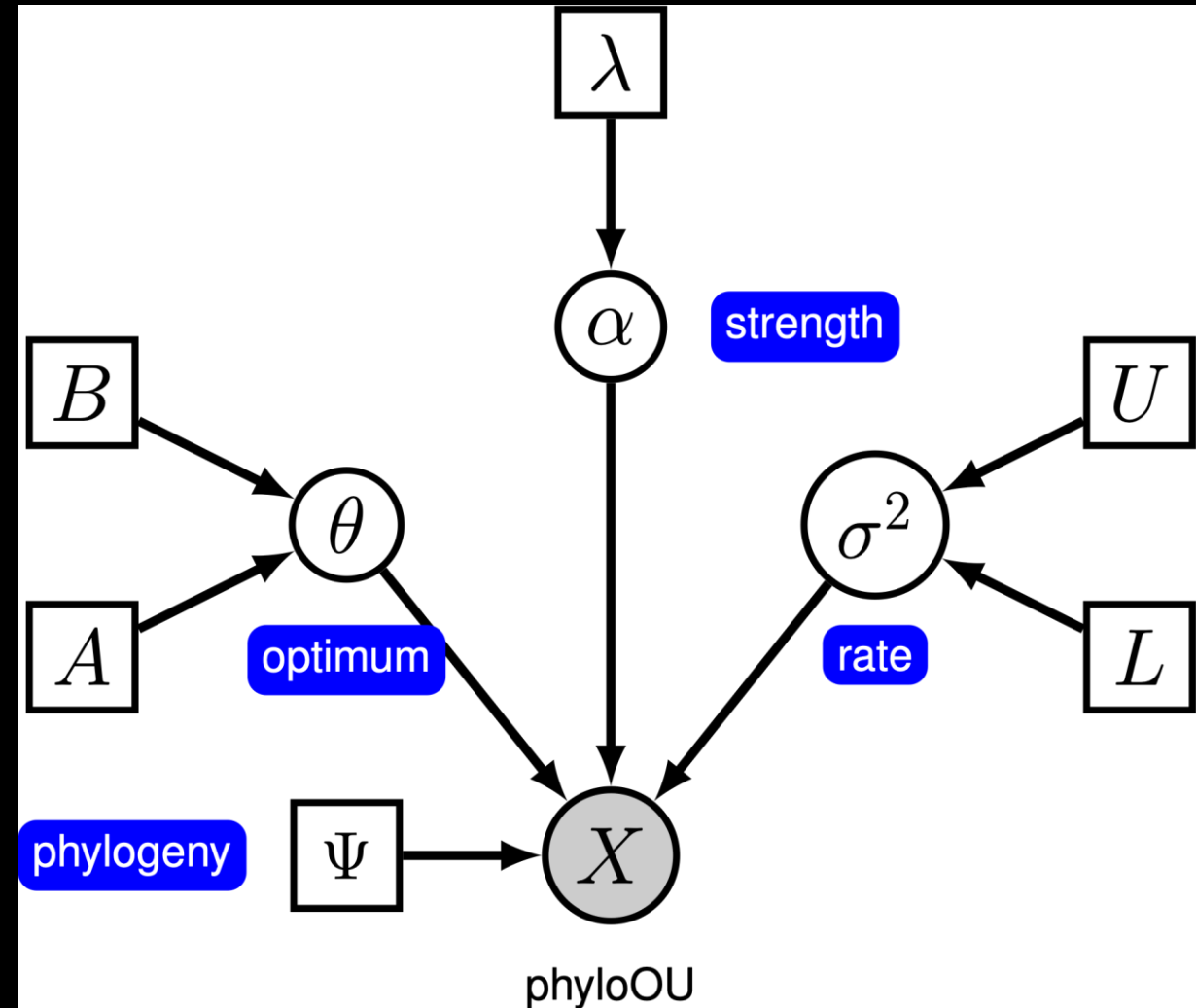

Biogeography: DEC

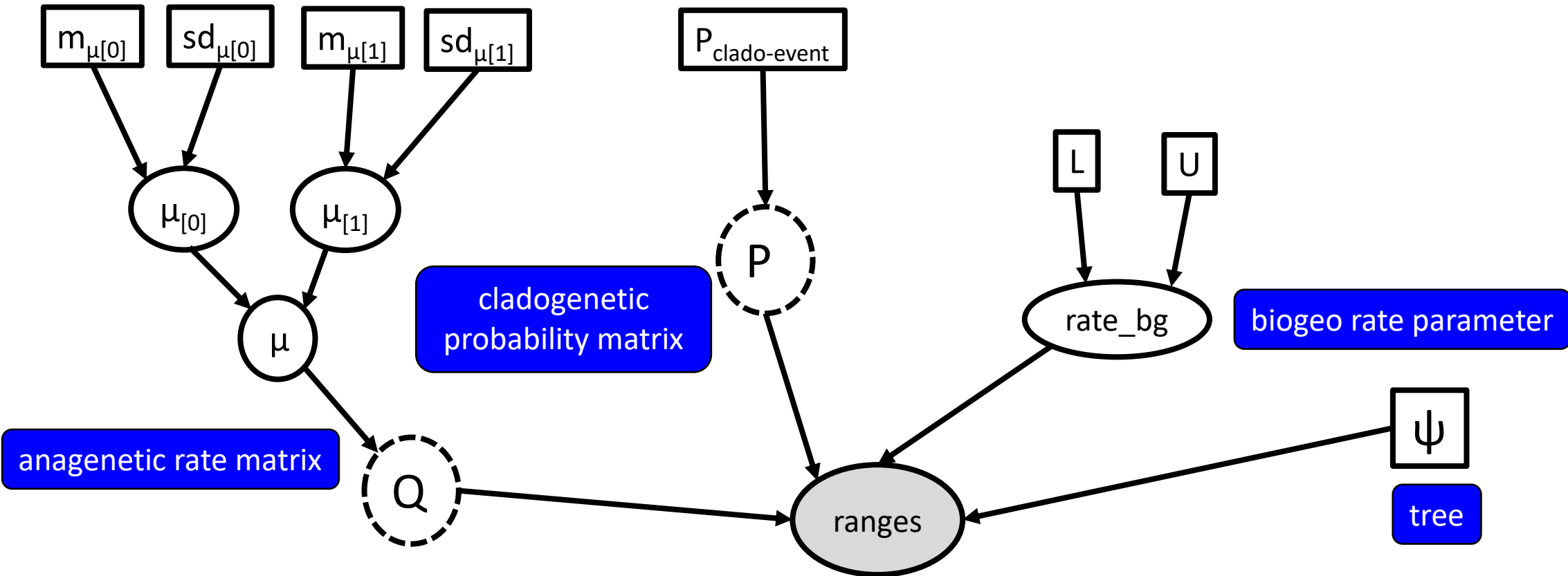

Diversification: Birth Death

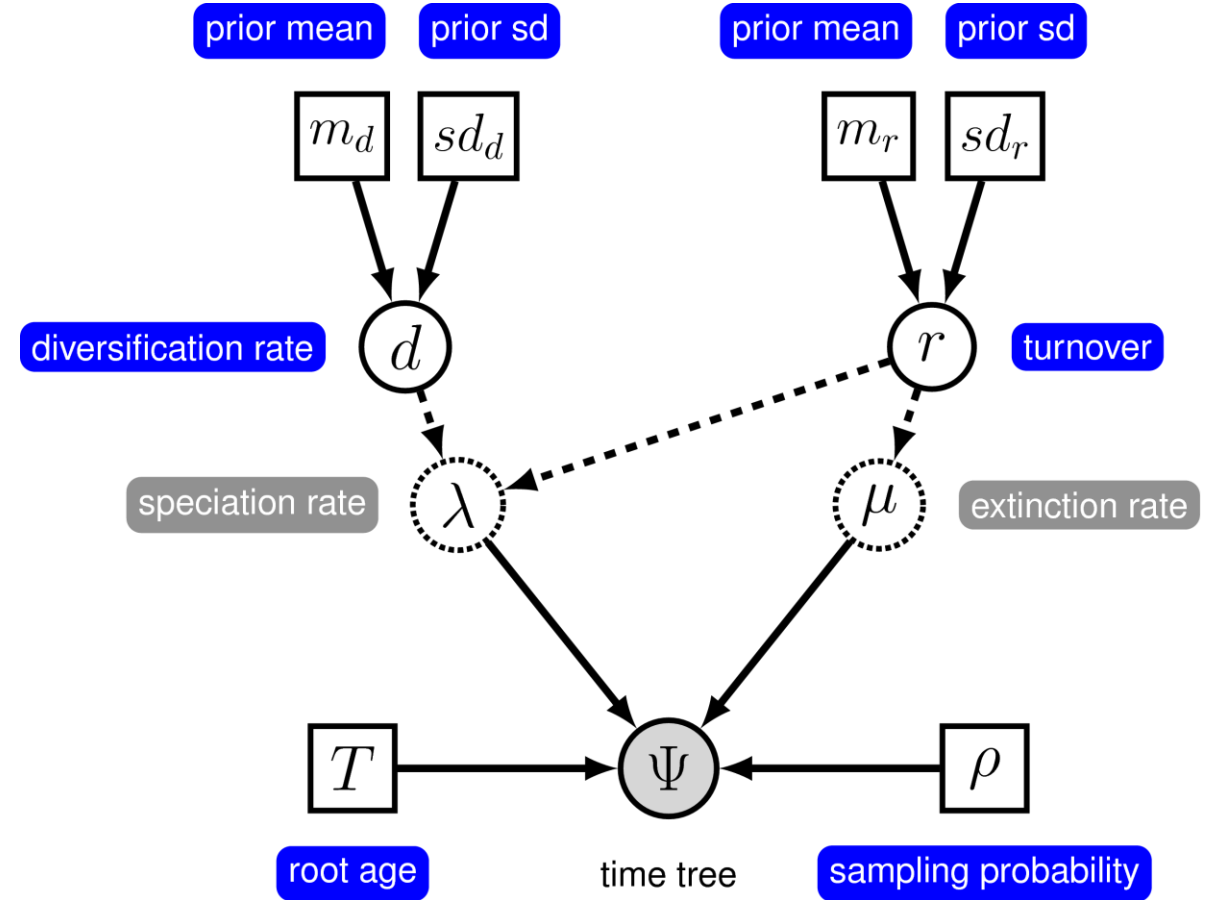
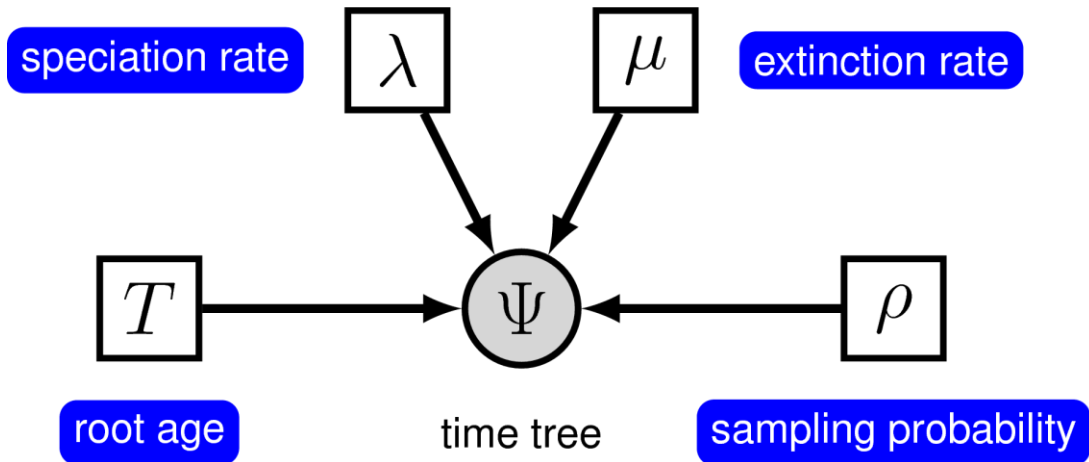

Diversification: BiSSE

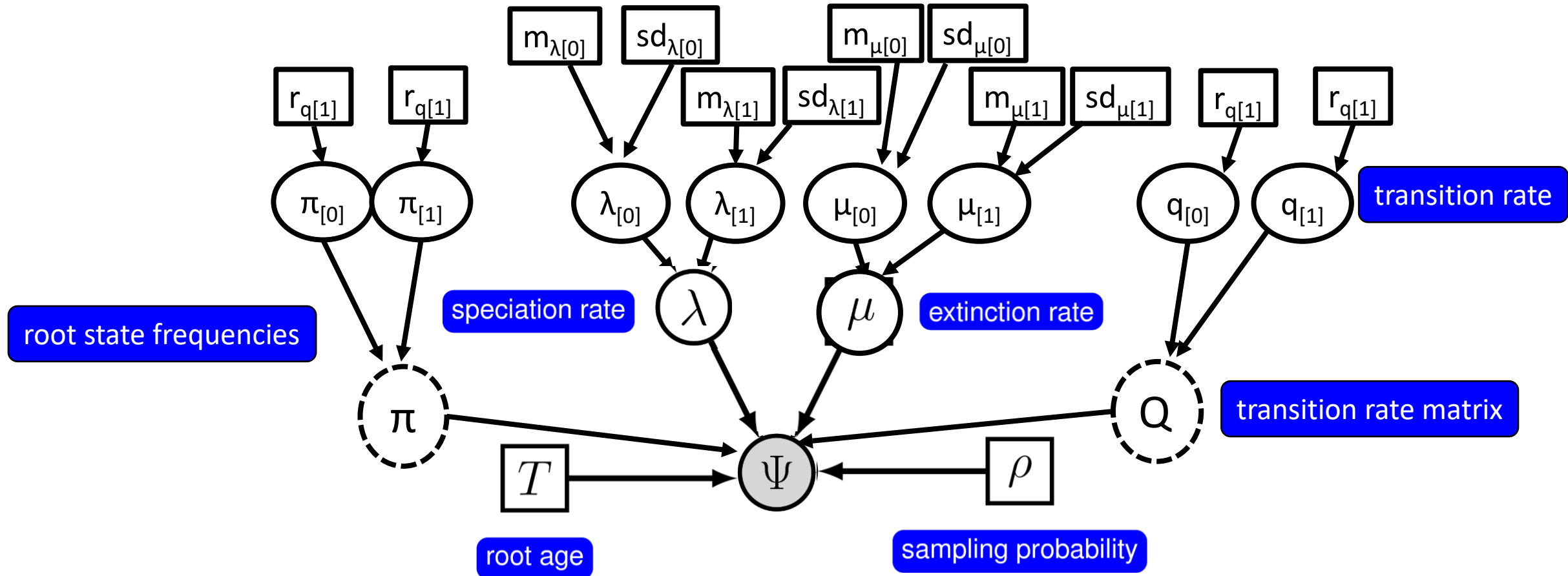

Diversification: MuSSE

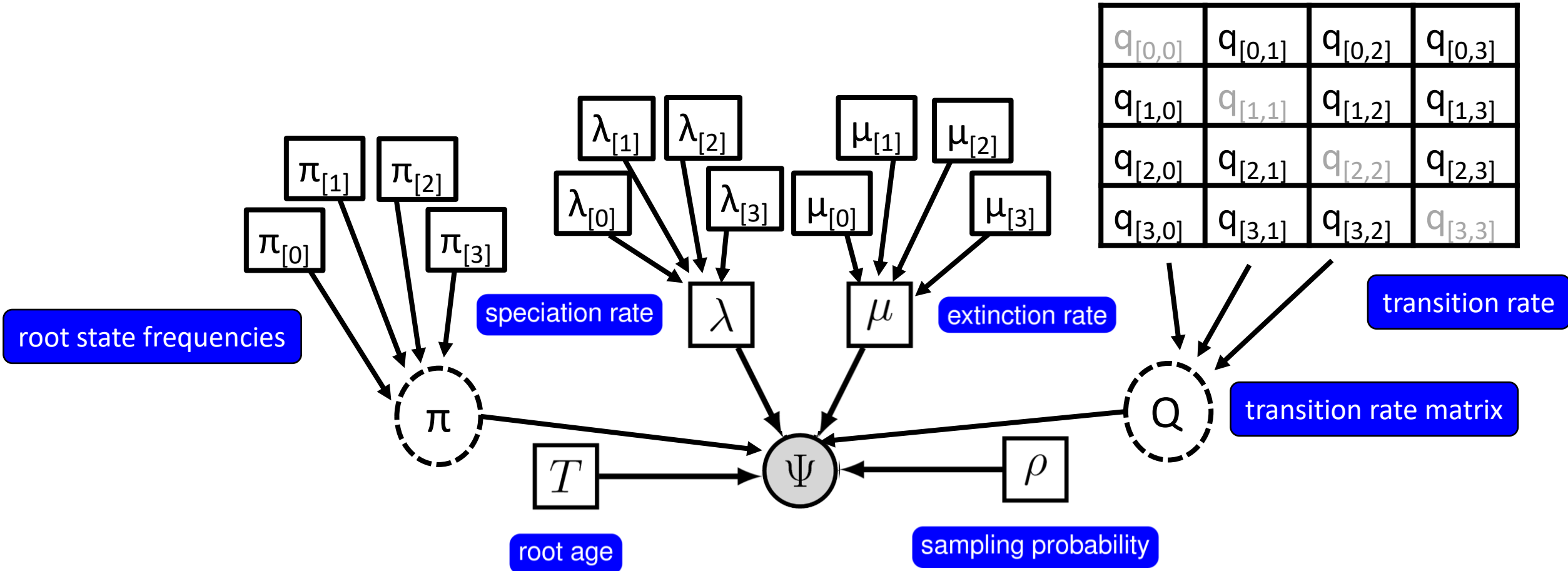

Diversification: CID-2

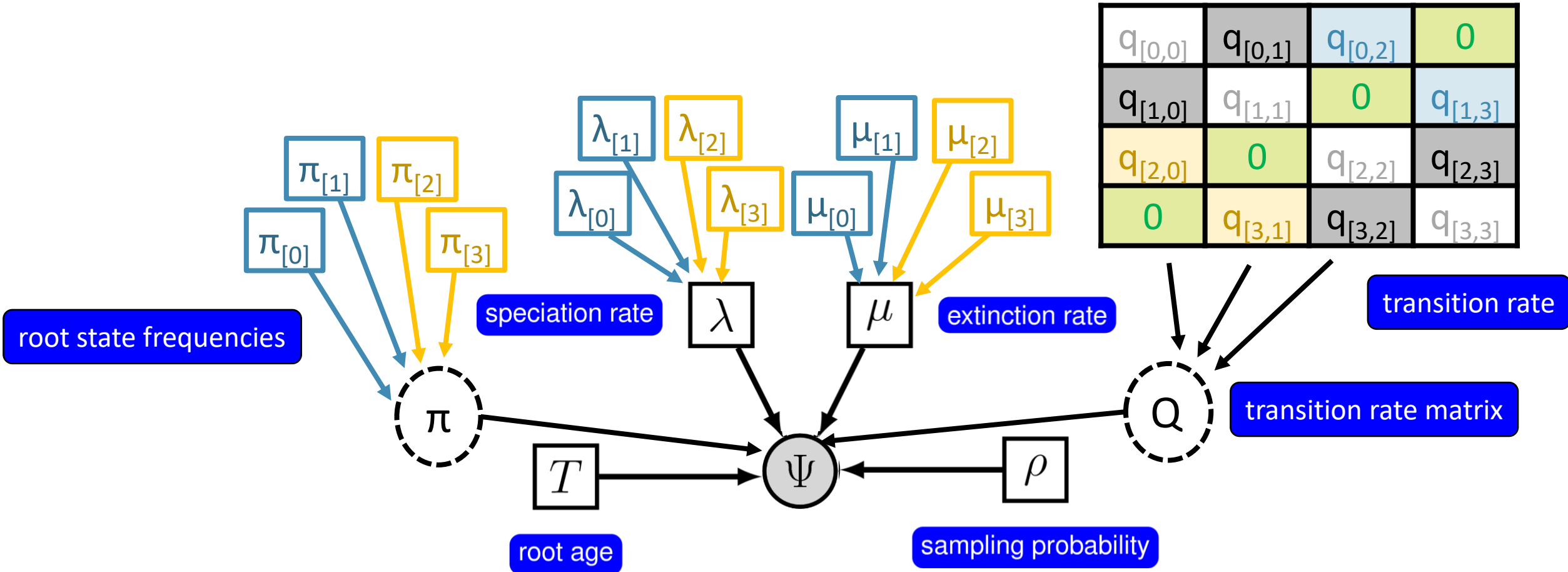

Tree Building & Dating: GTR Nucleotide Substitution Model

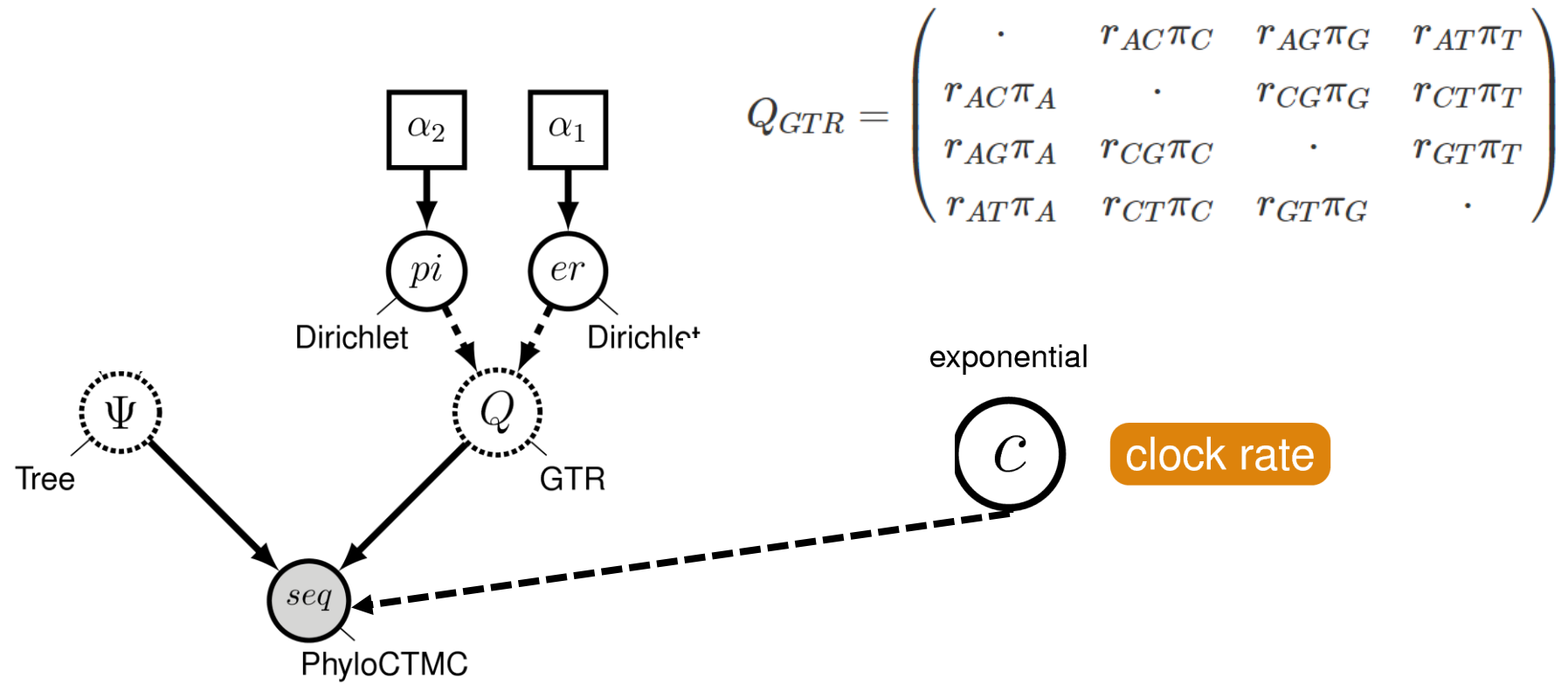

Tree Building & Dating: Tree Model

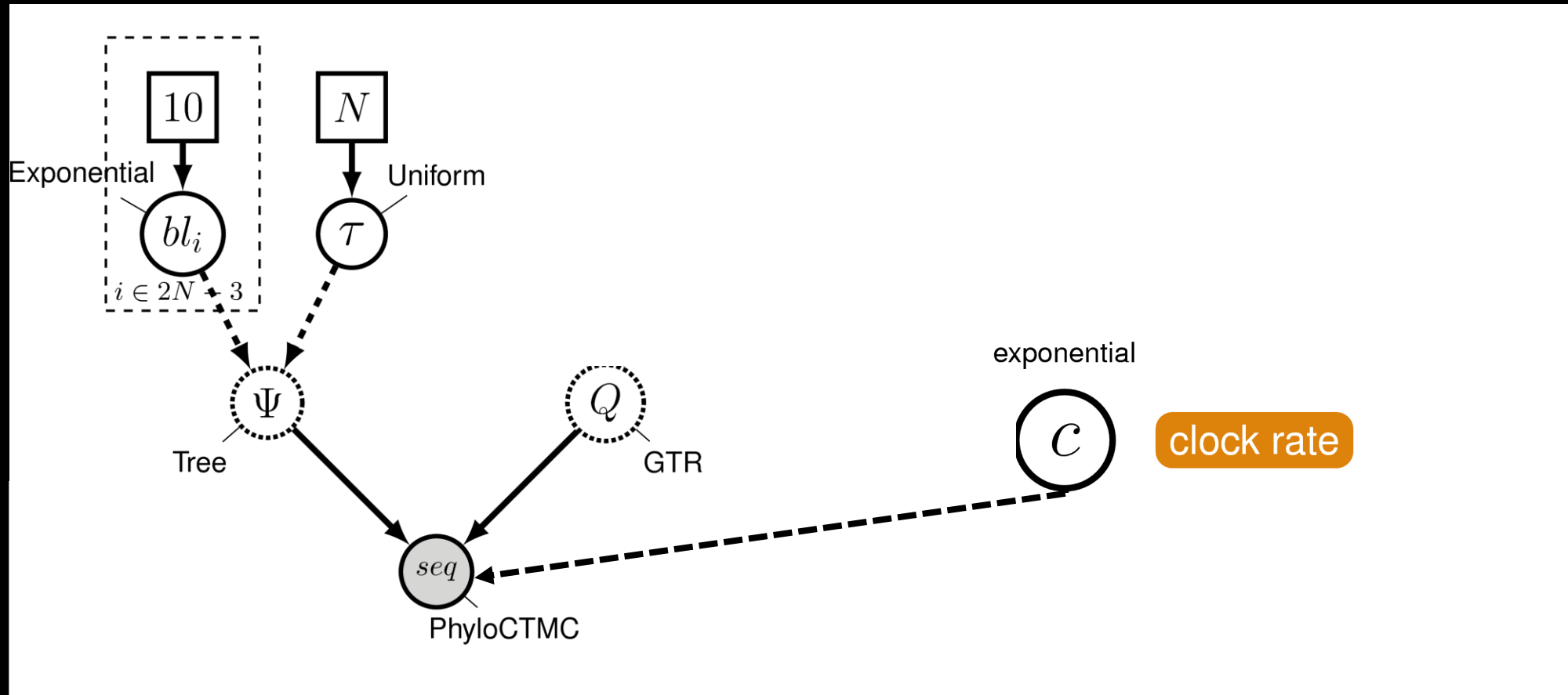

Tree Building & Dating: Global Molecular Clock

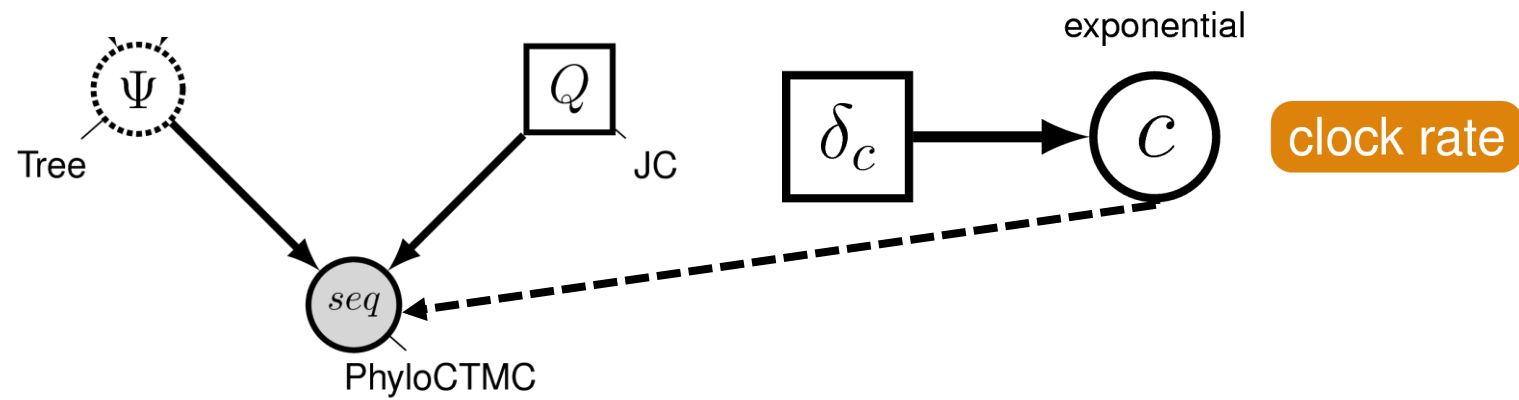

Tree Building & Dating:

BD – GTR – Global Molecular Clock

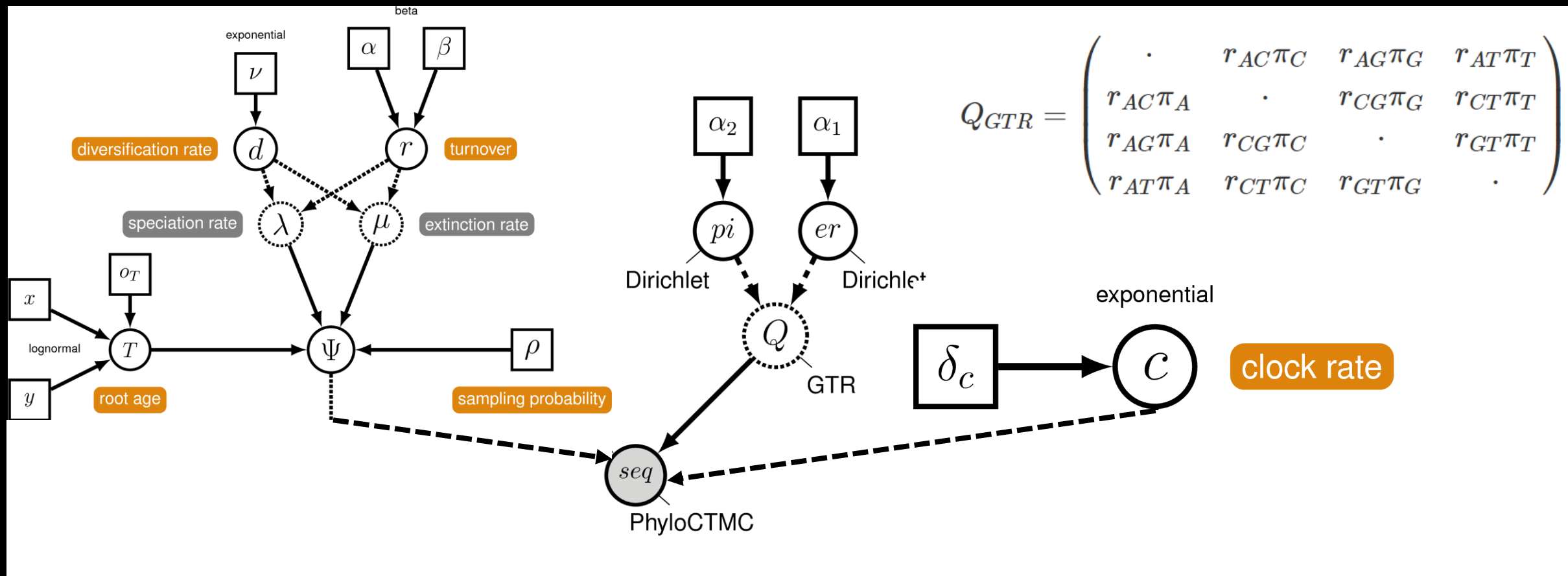

Tree Building & Dating:

BD – GTR – Relaxed Molecular Clock

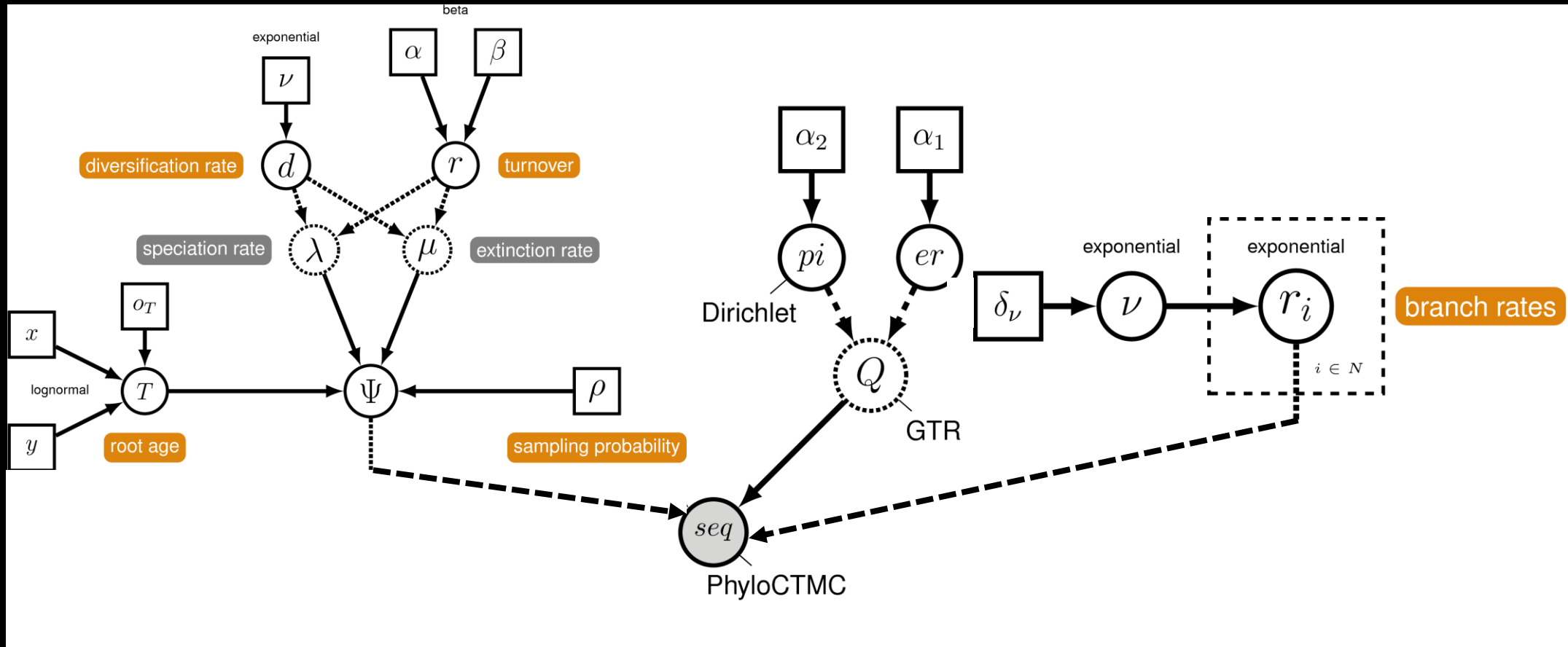

Our Models

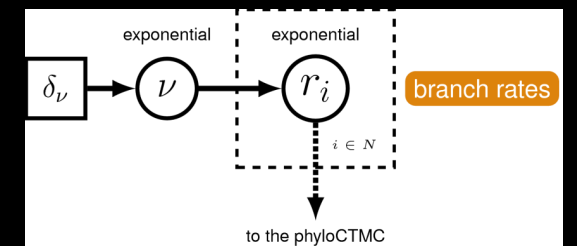
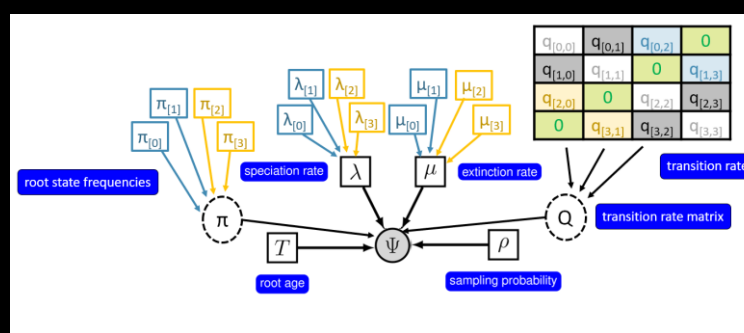
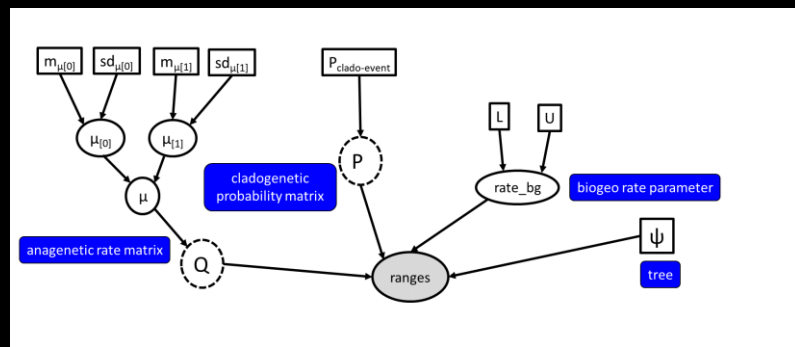
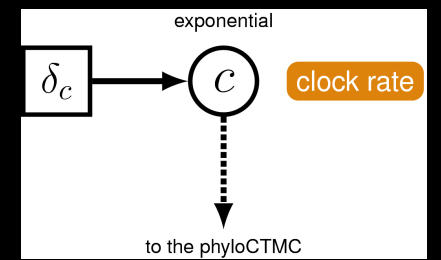
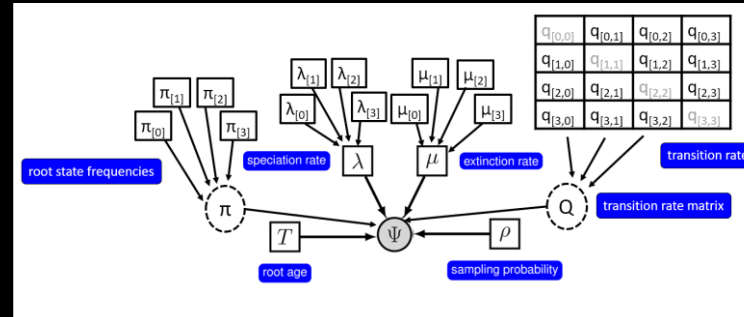
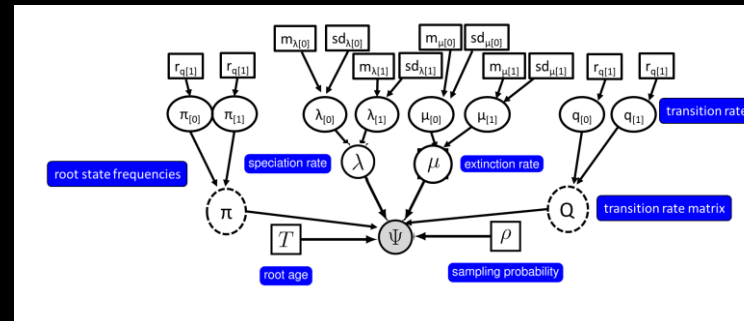
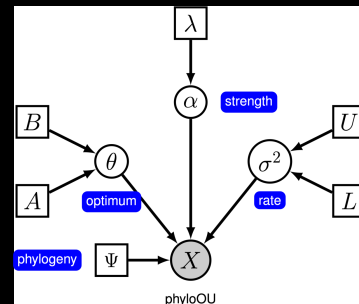
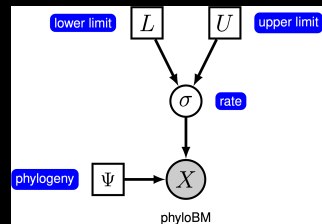
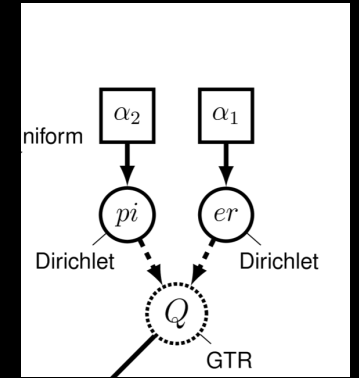
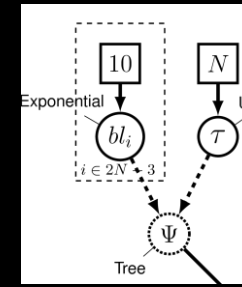
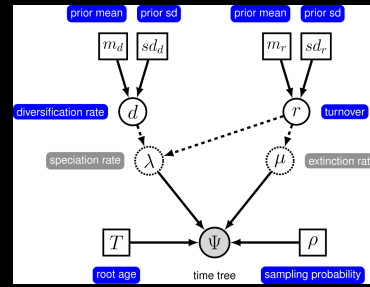

Our Models

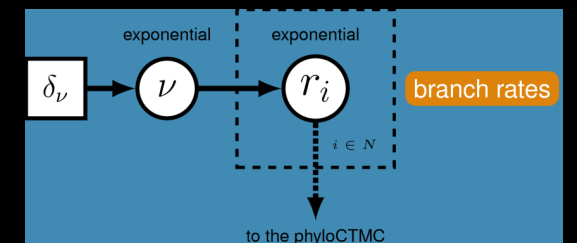
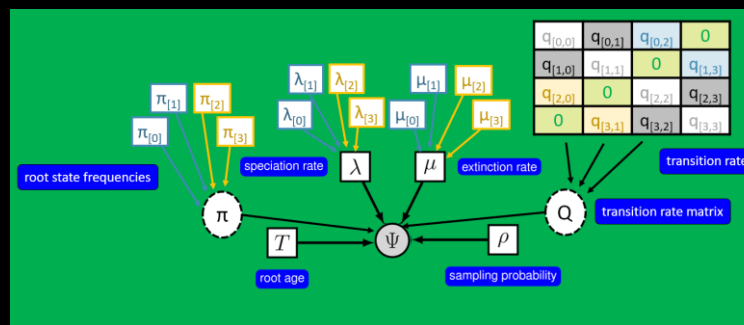
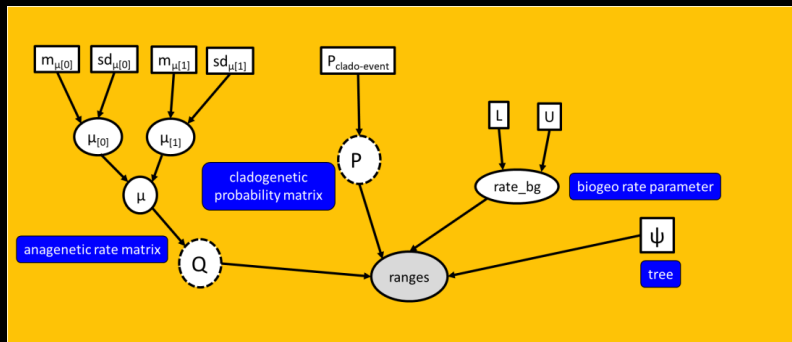
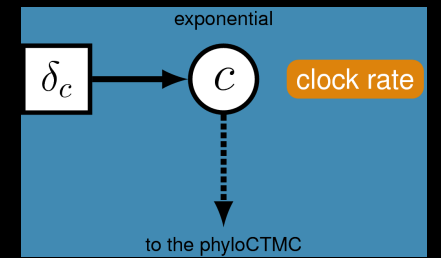
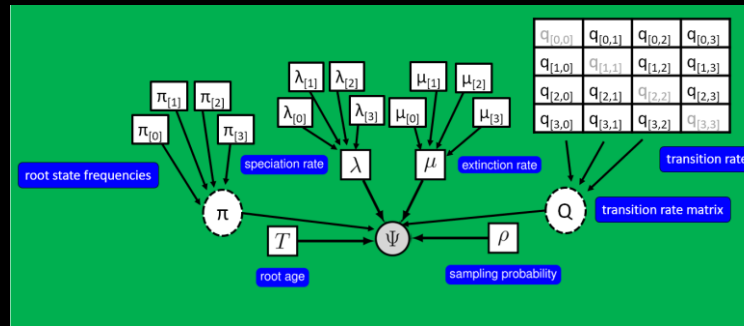
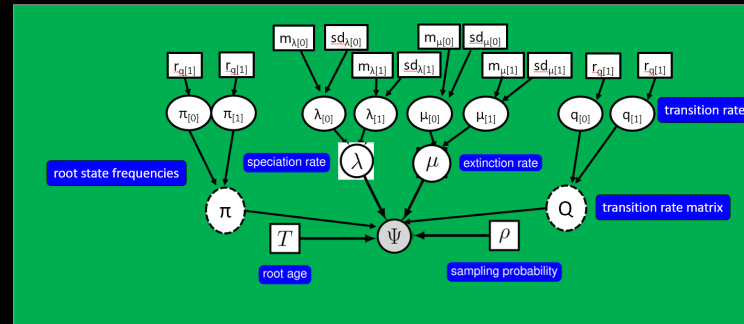
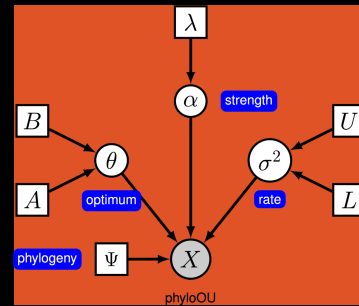
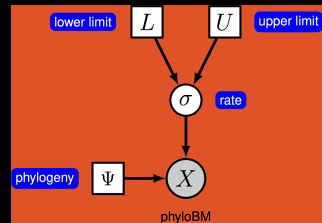
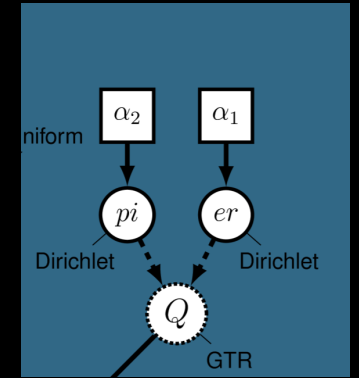
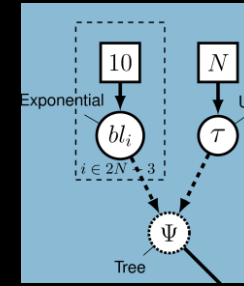
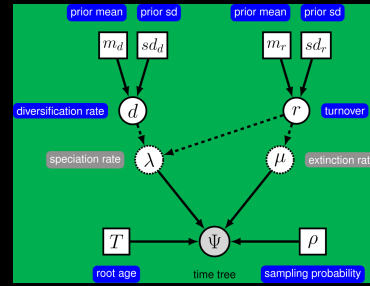

Our Models

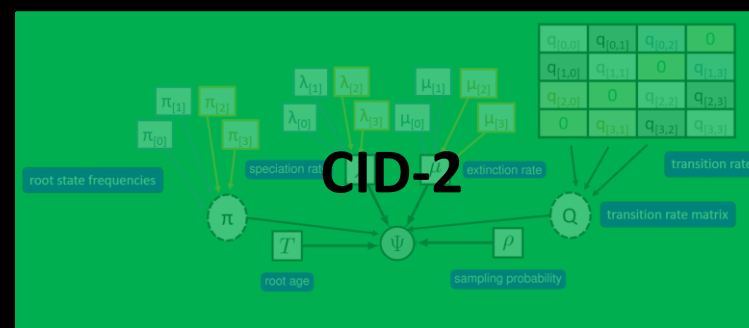
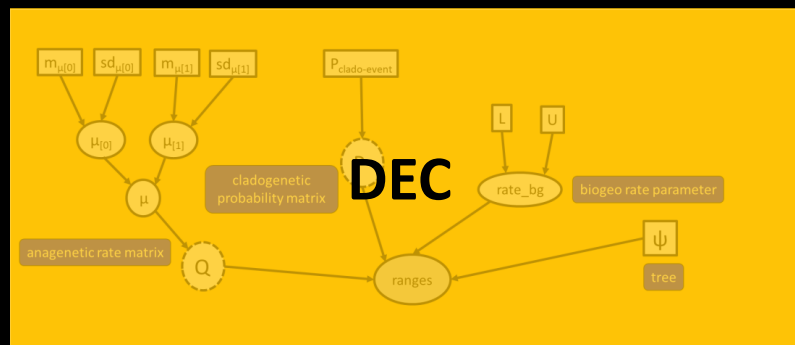
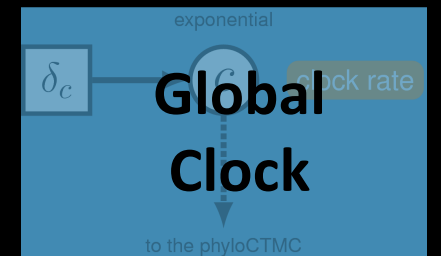
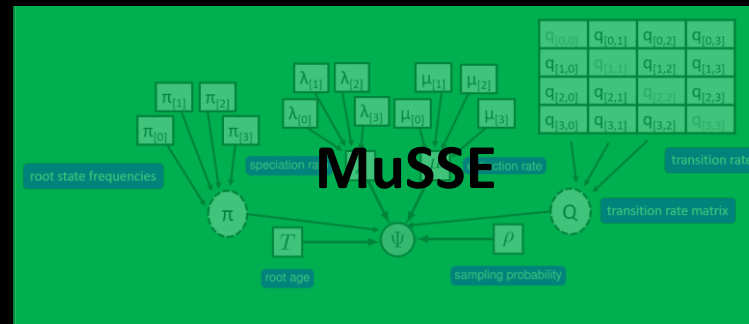
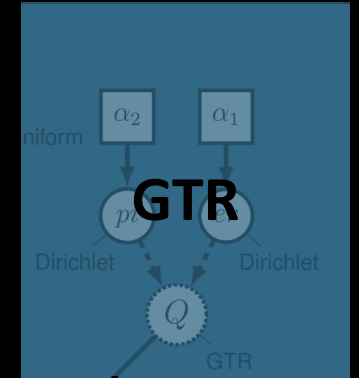
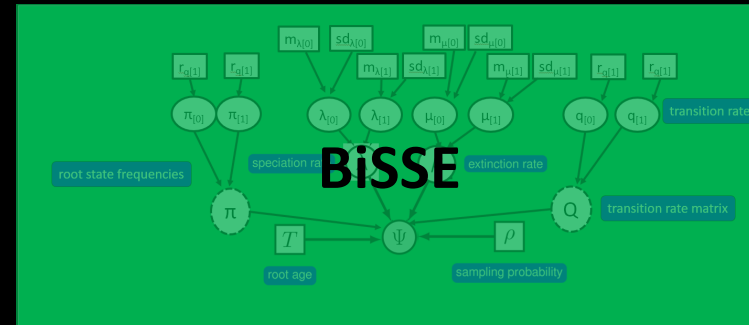
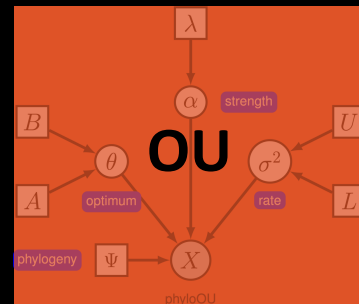
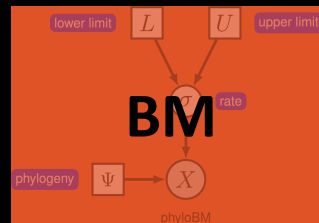
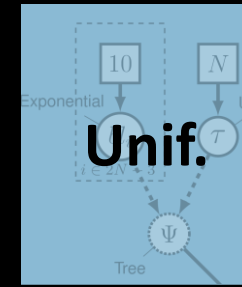
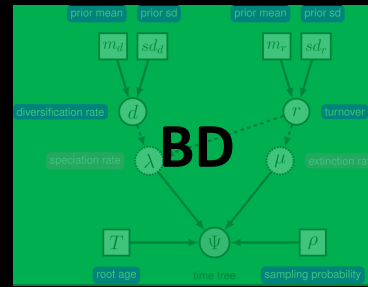

Syntax and more...

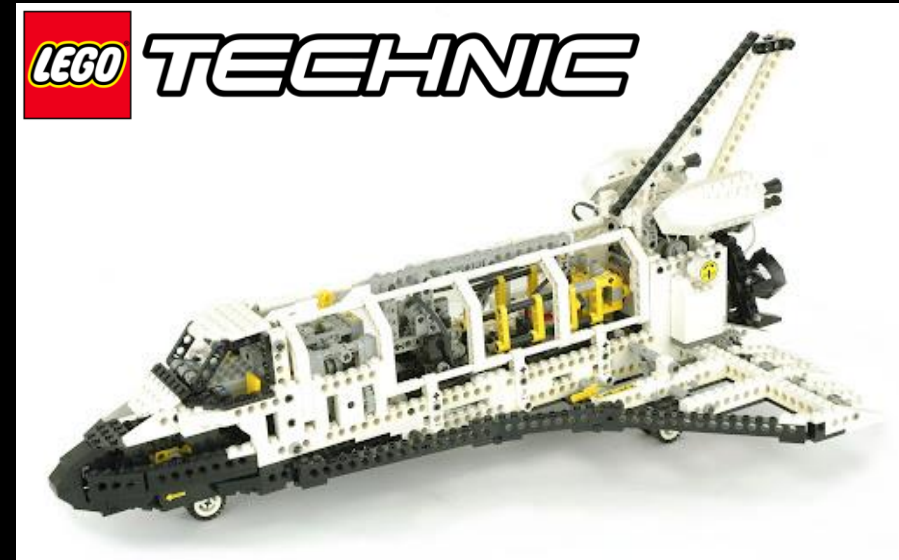
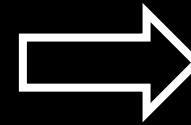
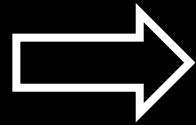

BD – GTR – Relaxed Molecular Clock

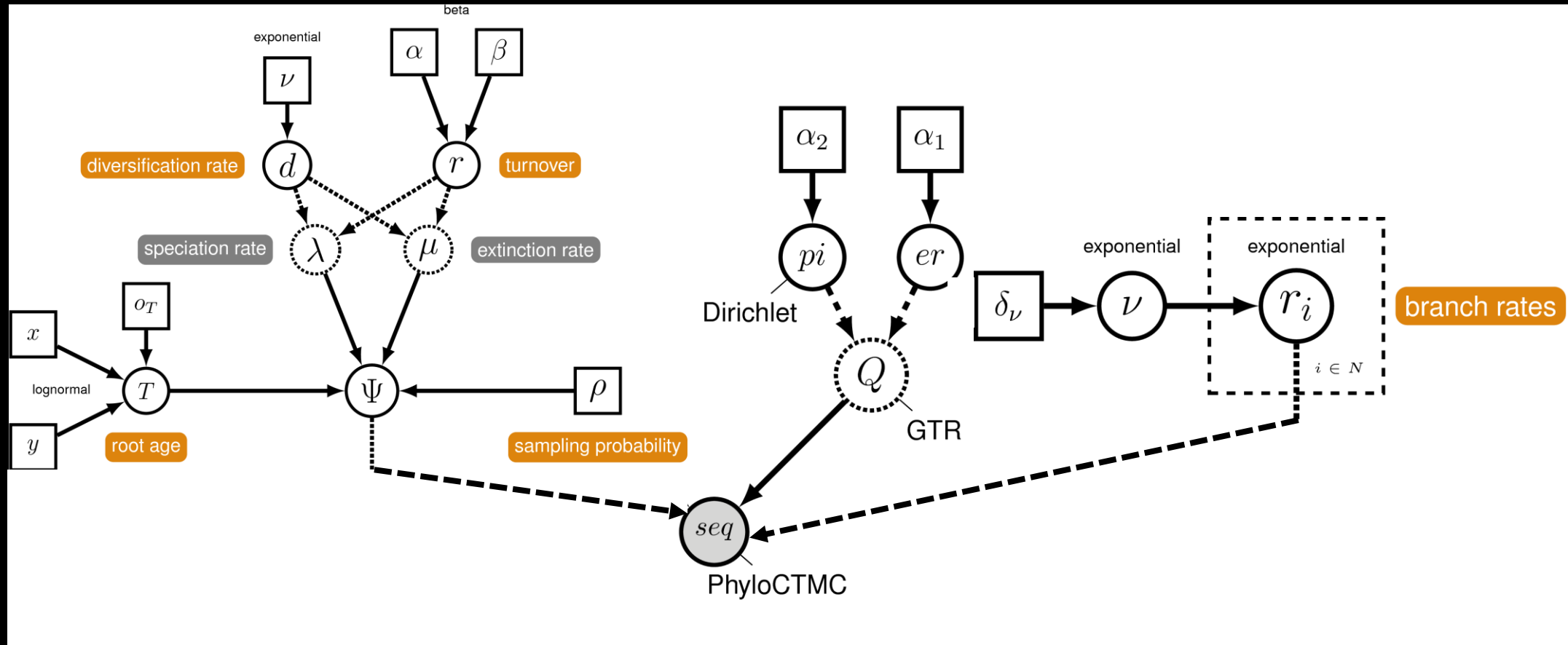

BD – GTR – Relaxed Molecular Clock

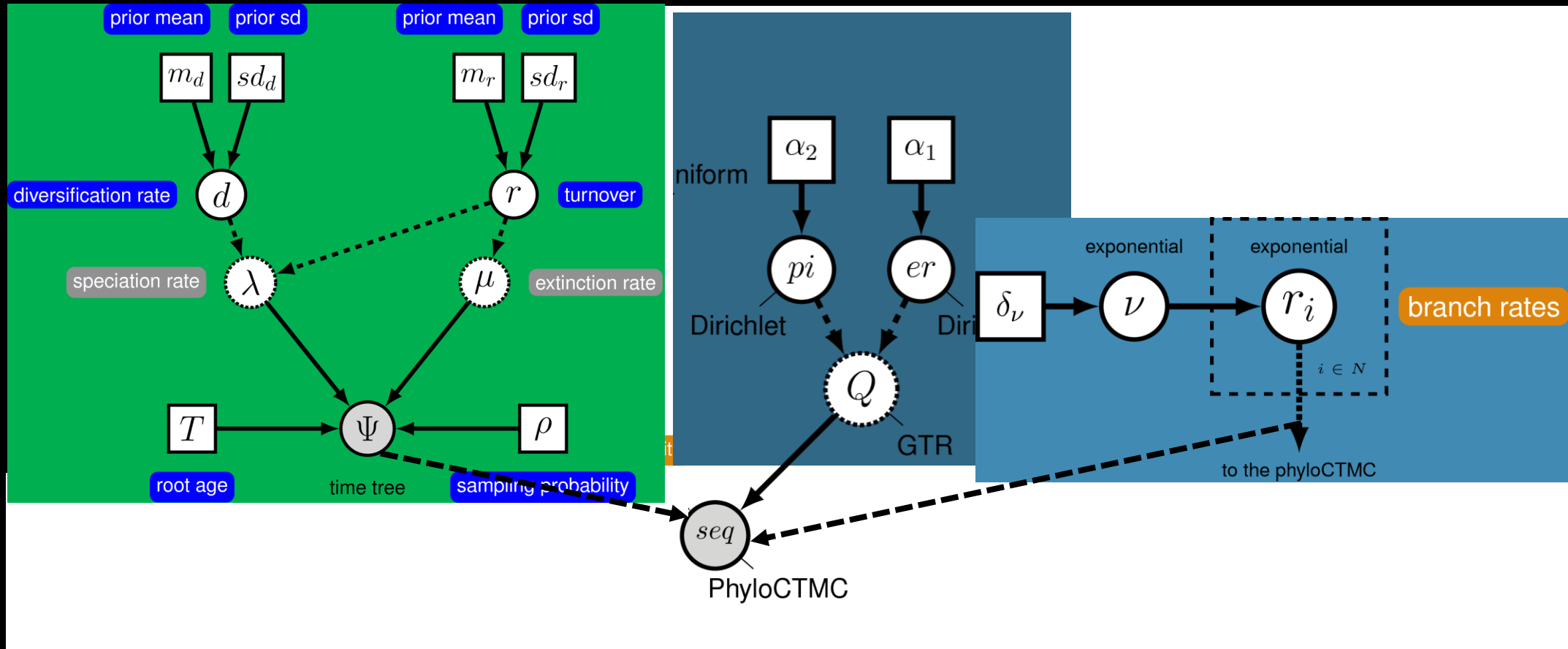

Build & Date Tree with BiSSE

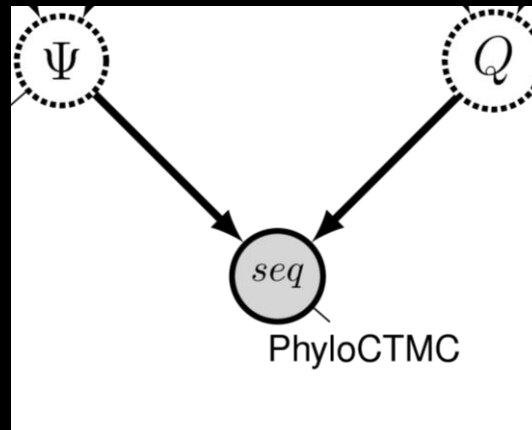
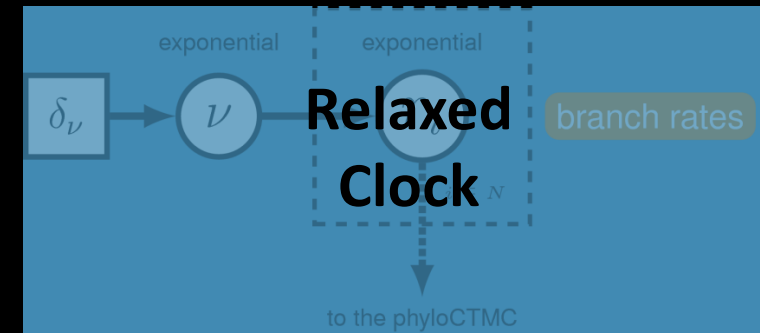
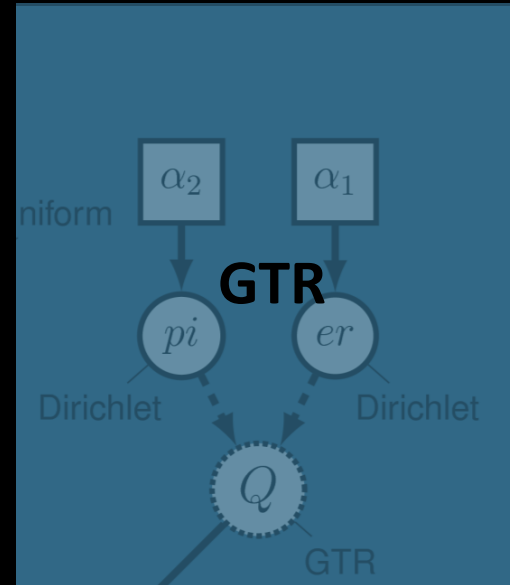
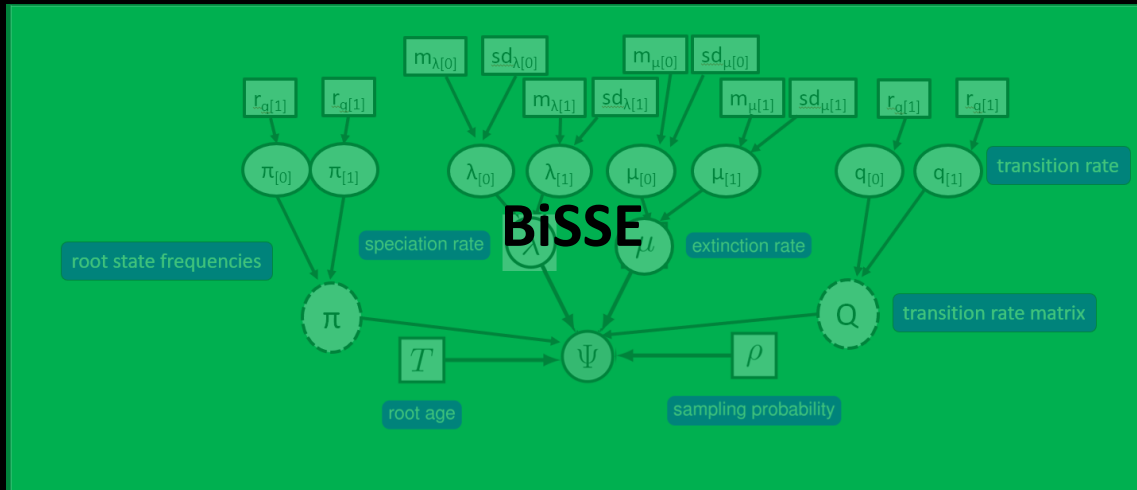

Build & Date Tree with BiSSE

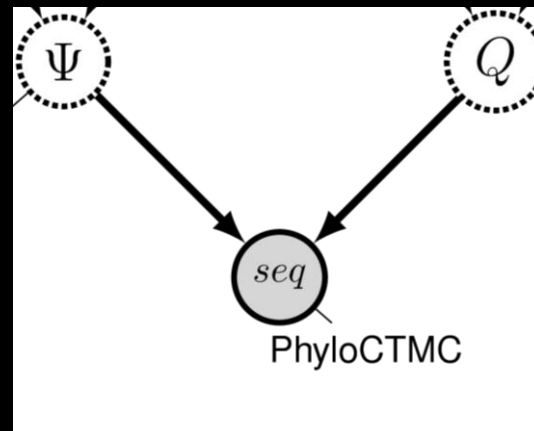
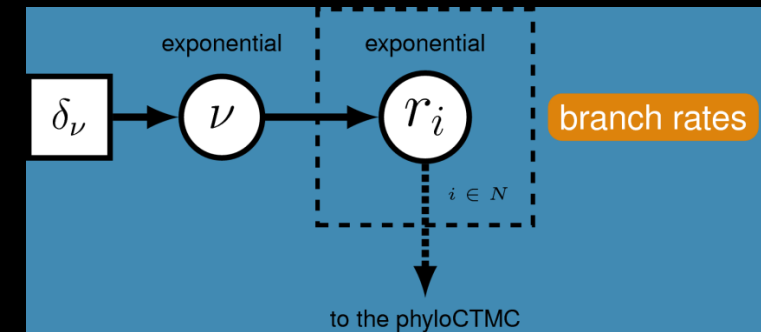
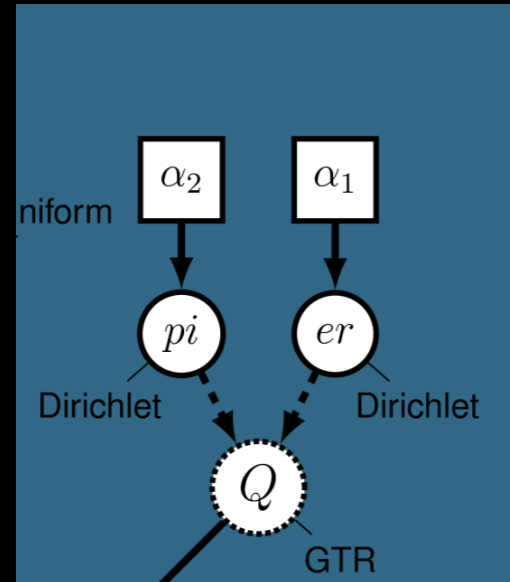
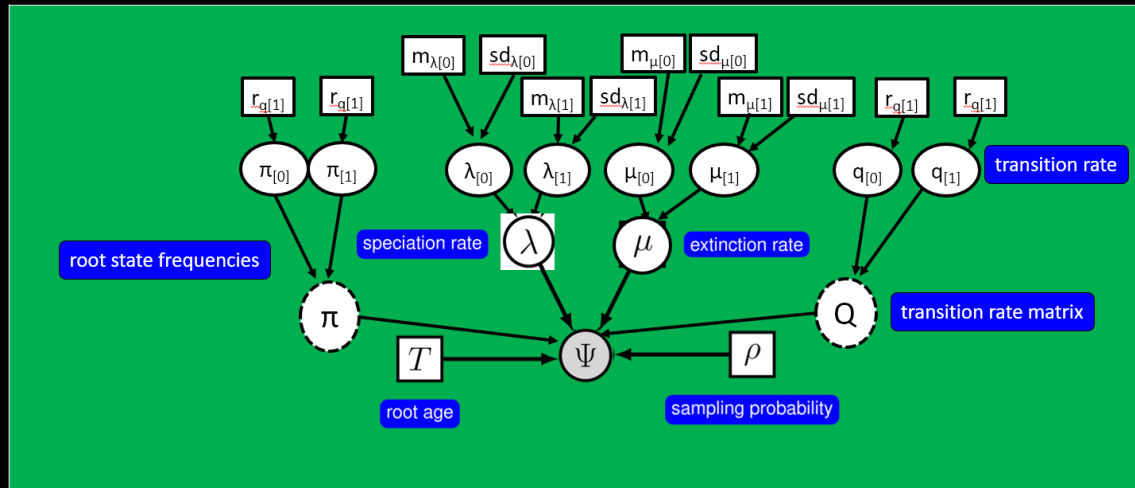

Build & Date Tree with BiSSE

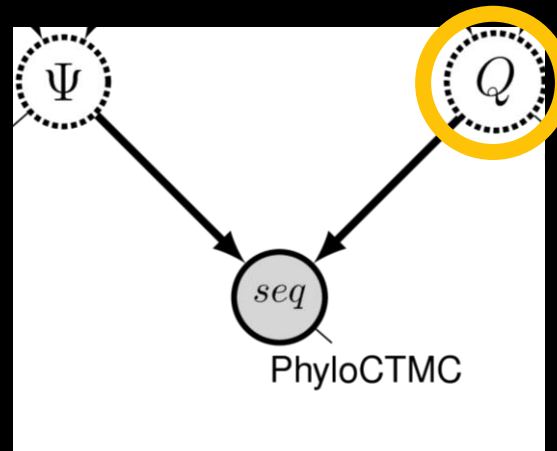
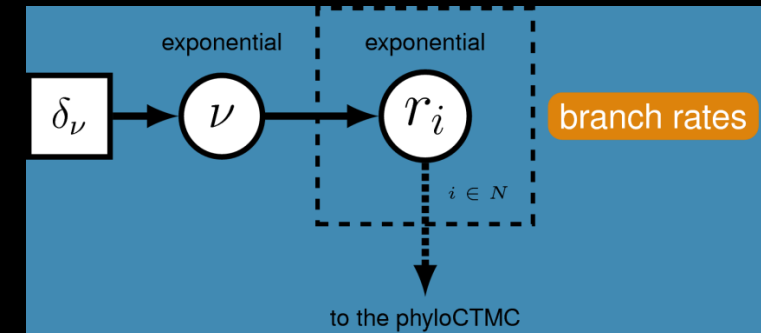
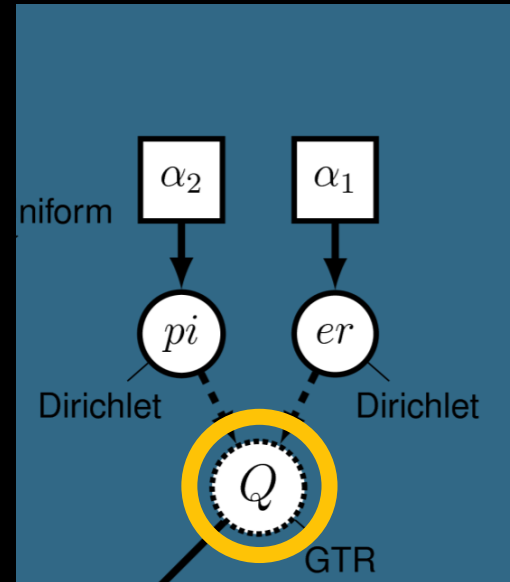
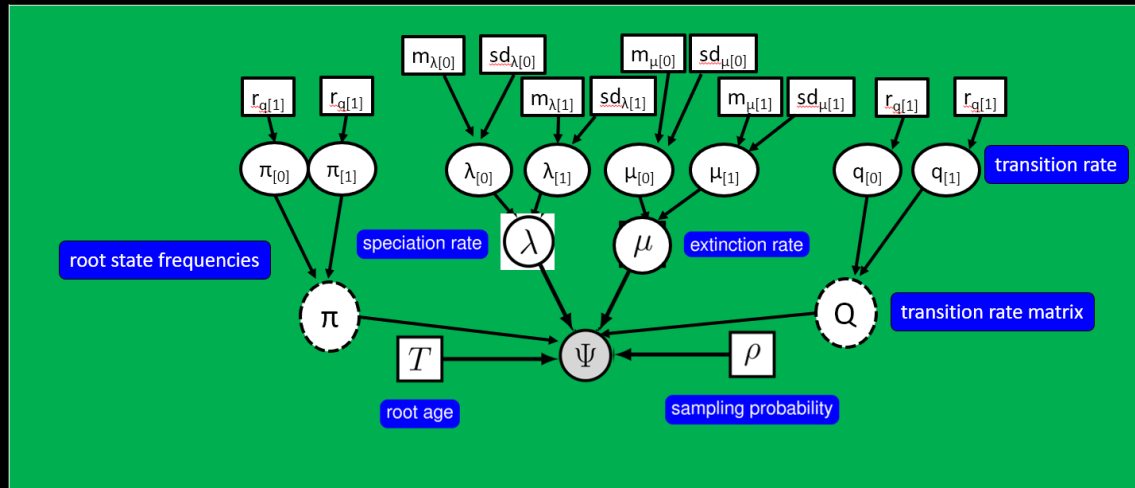

Build & Date Tree with BiSSE

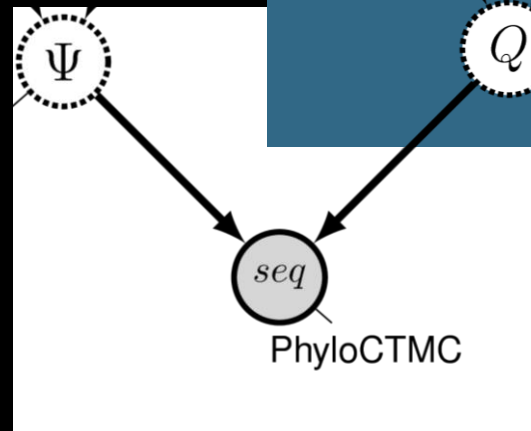
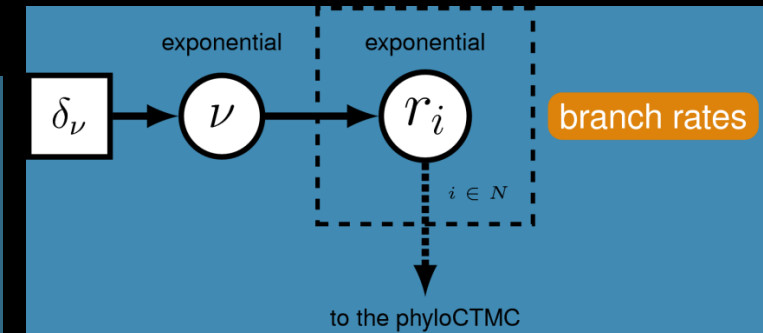
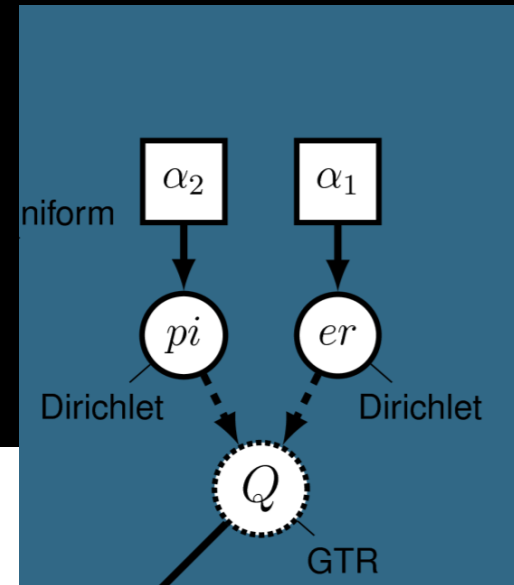
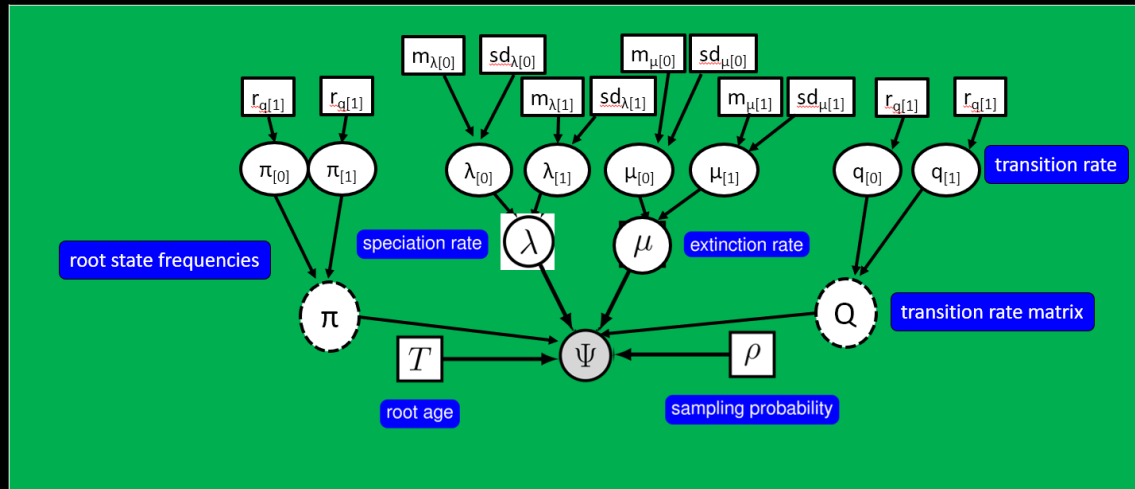

Build & Date Tree with BiSSE

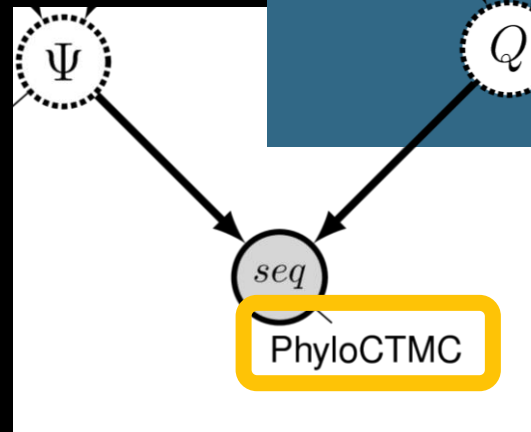
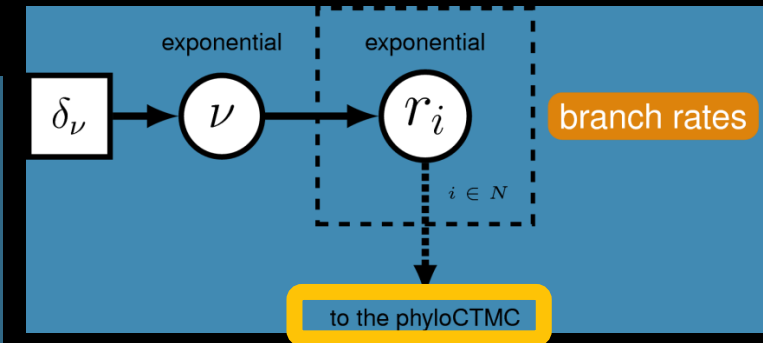
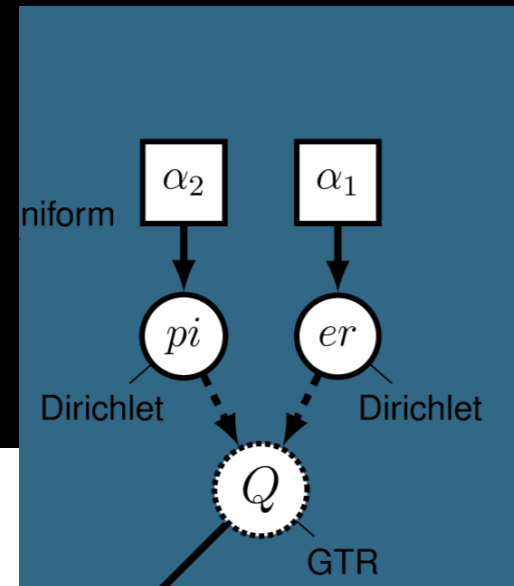
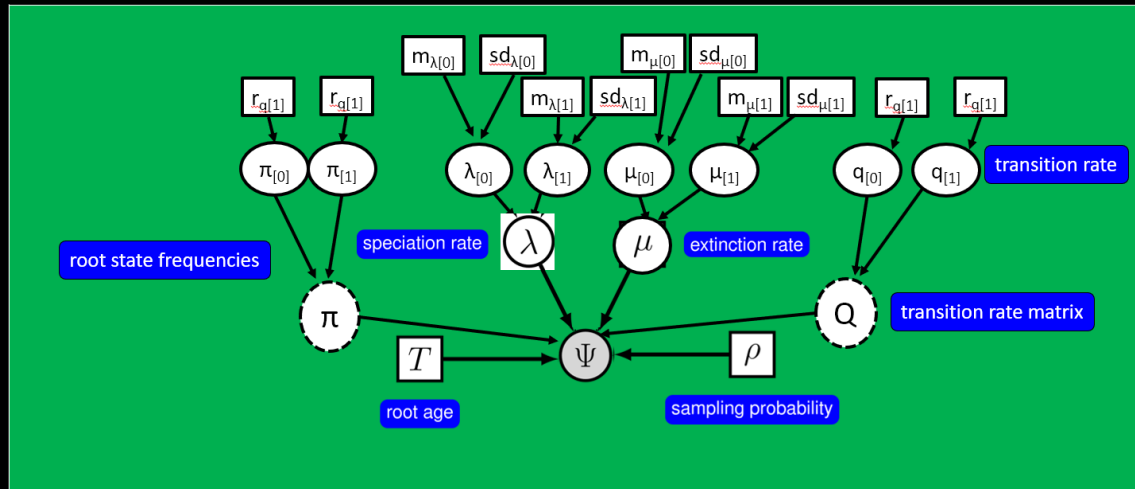

Build & Date Tree with BiSSE

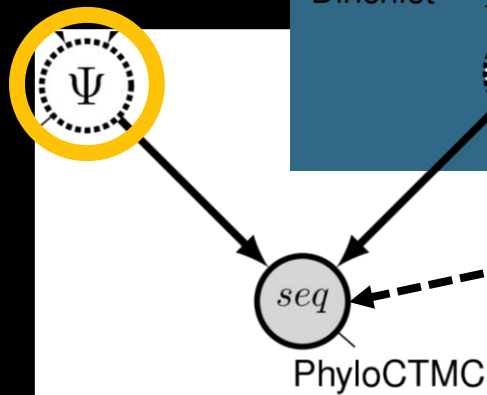
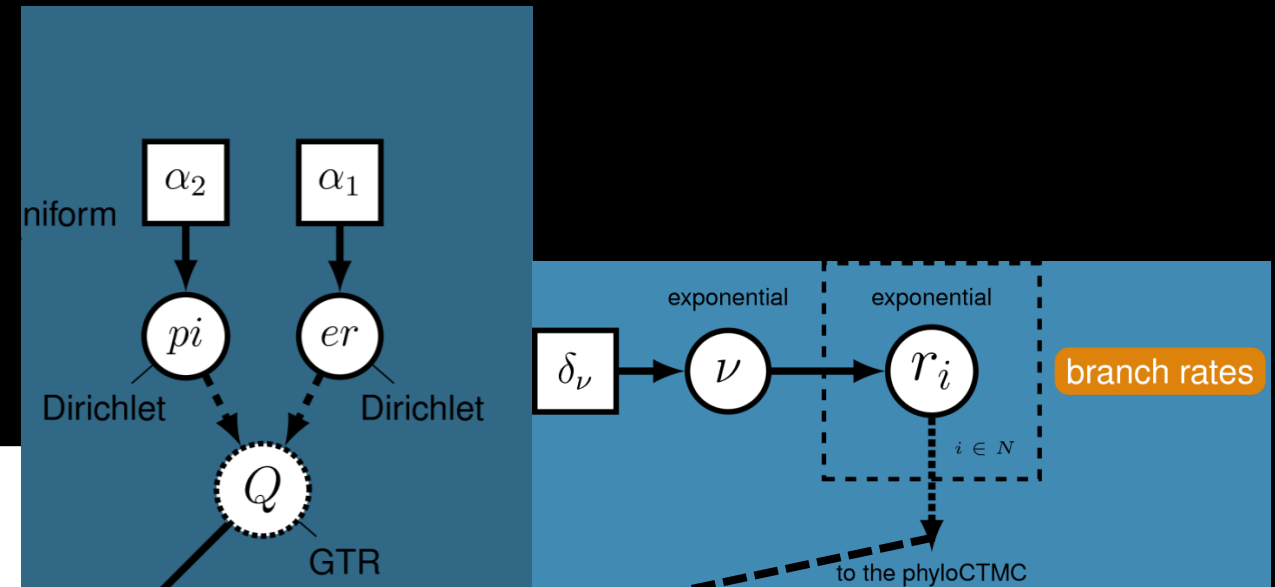
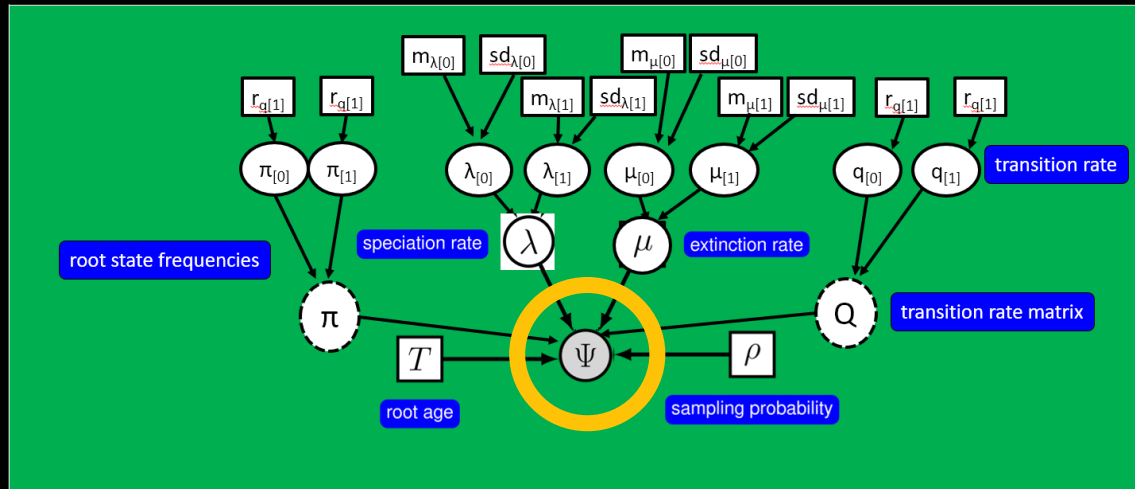

Build & Date Tree with BiSSE

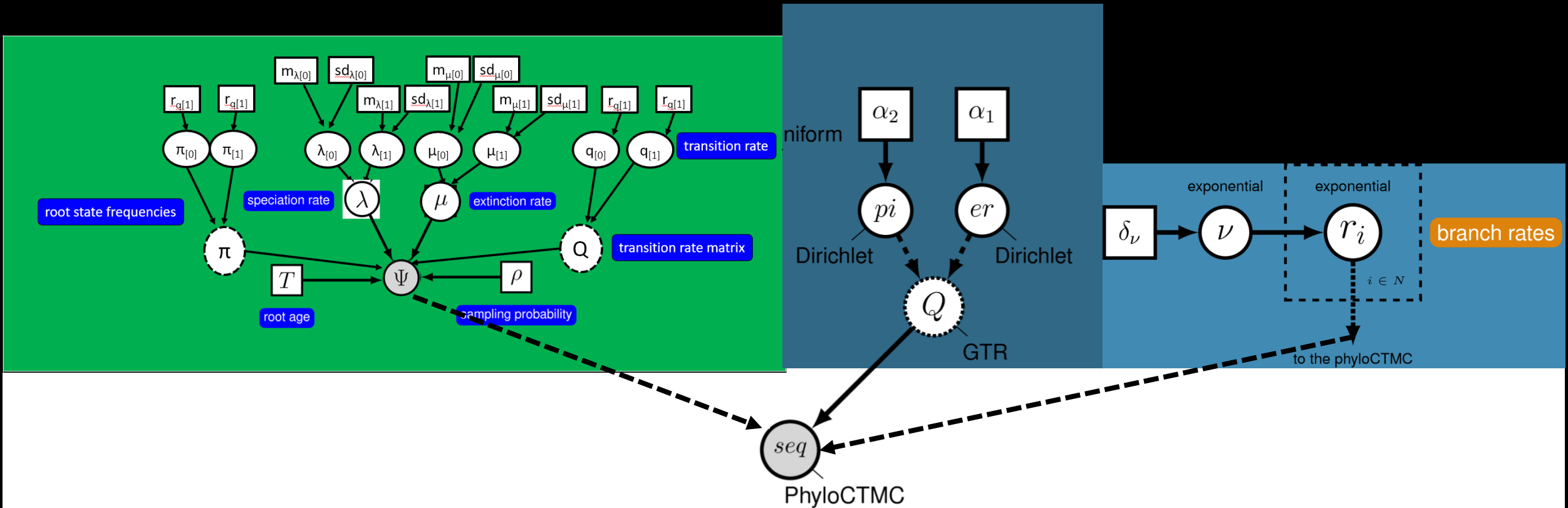

BD – GTR – Relaxed Molecular Clock

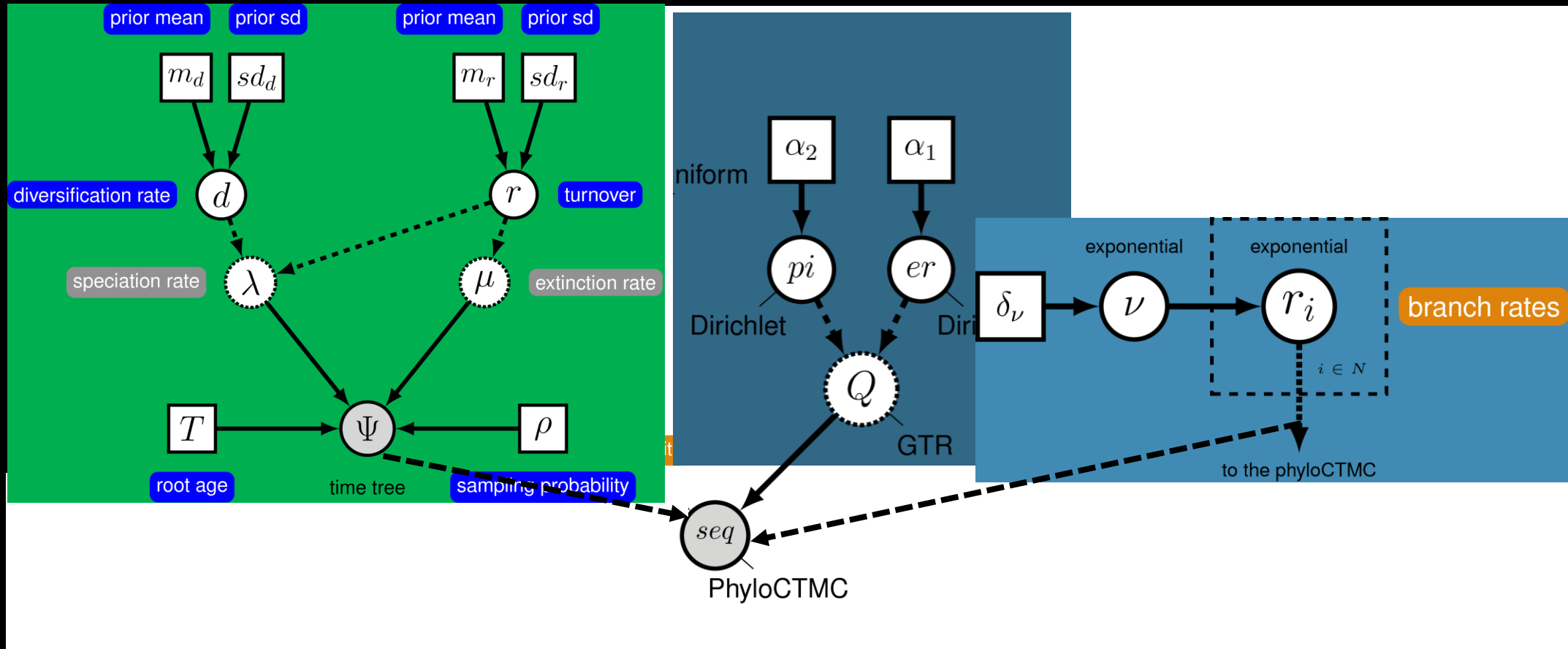

Build & Date Tree with BiSSE

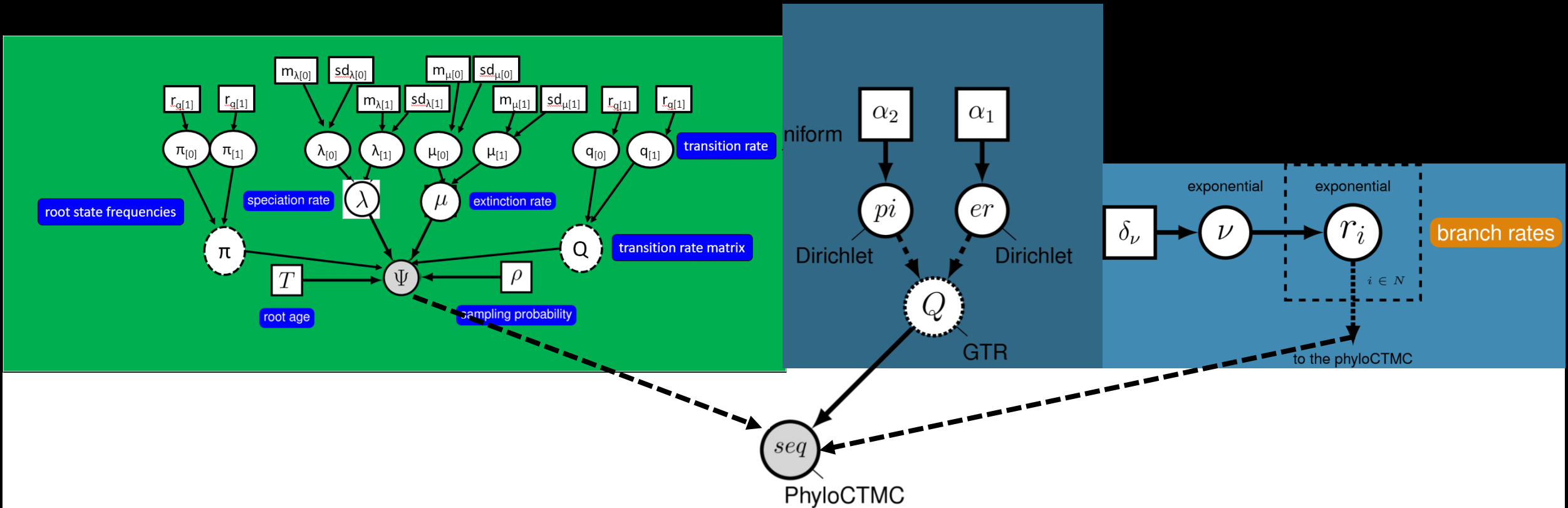

Build & Date Tree with BiSSE

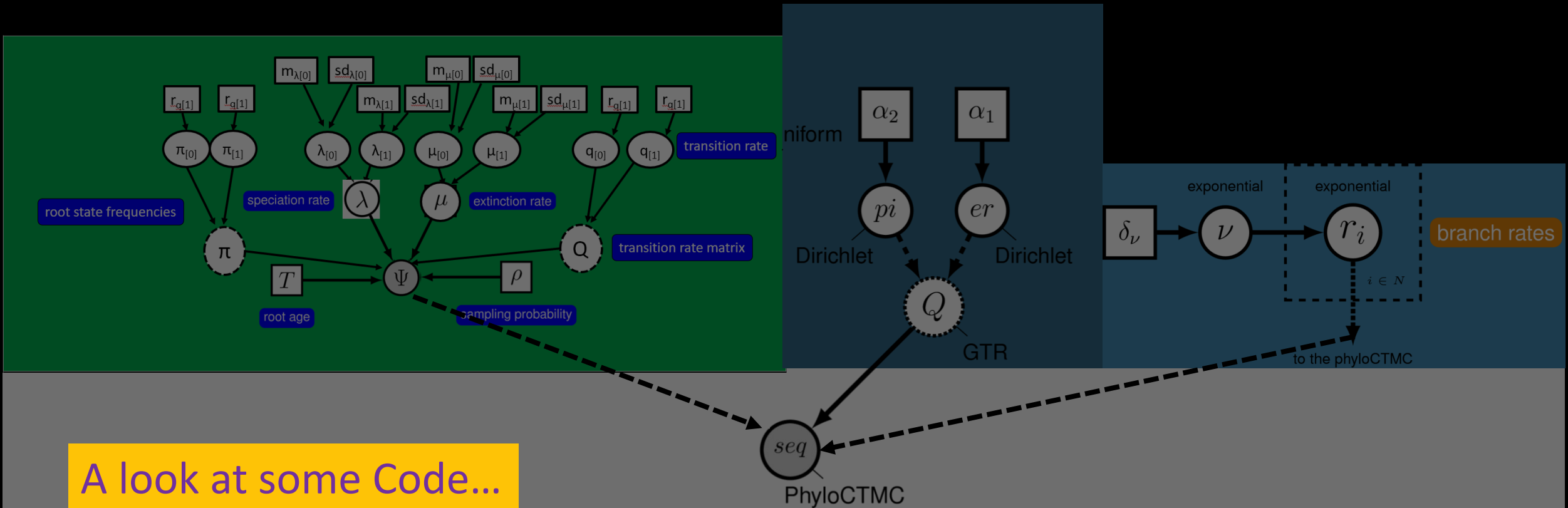

A look at some Code...

Stratigraphic Dating

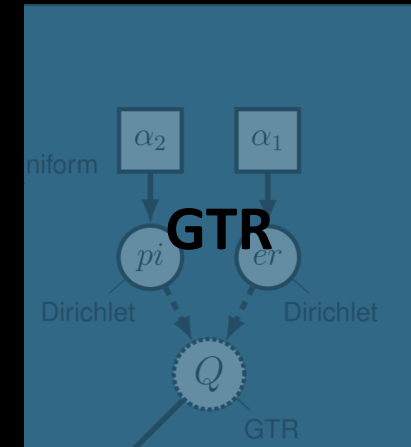
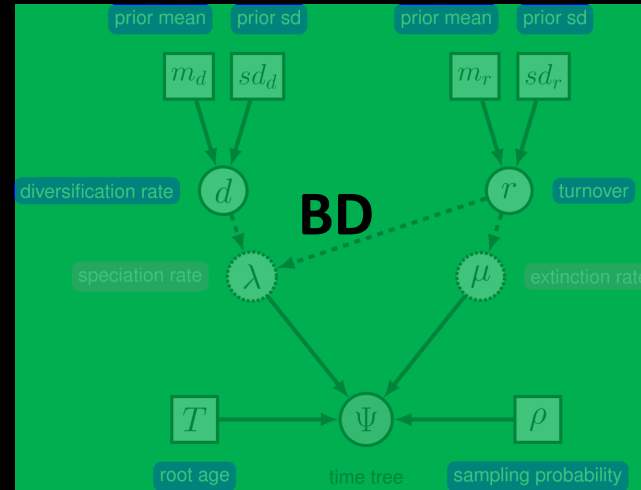
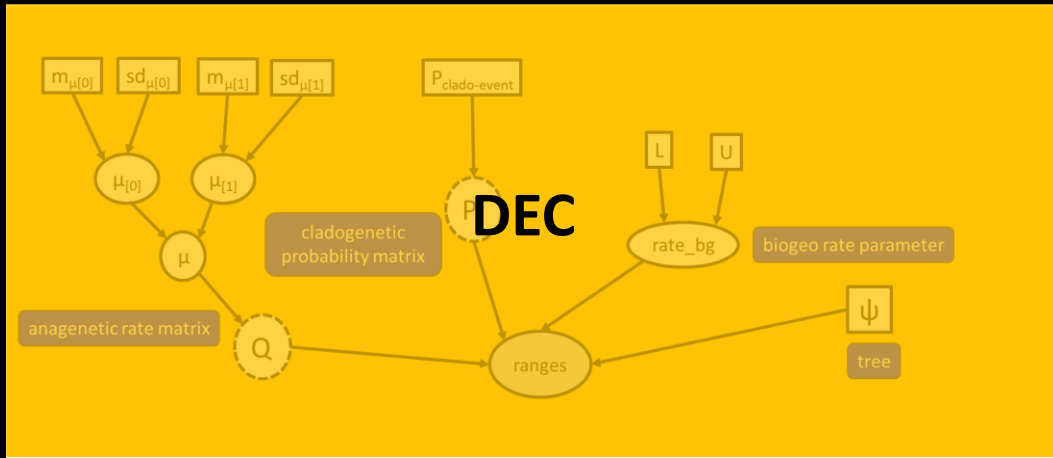

Stratigraphic Dating

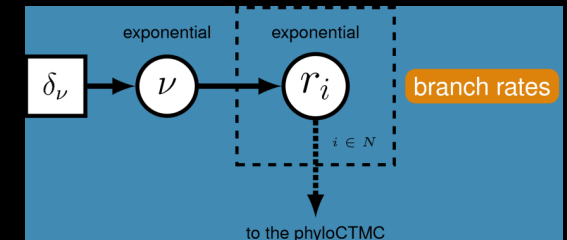
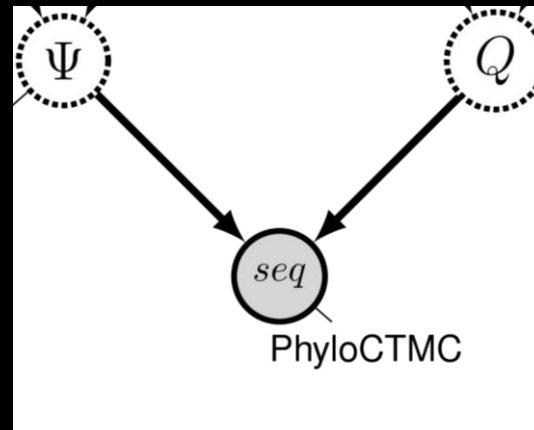
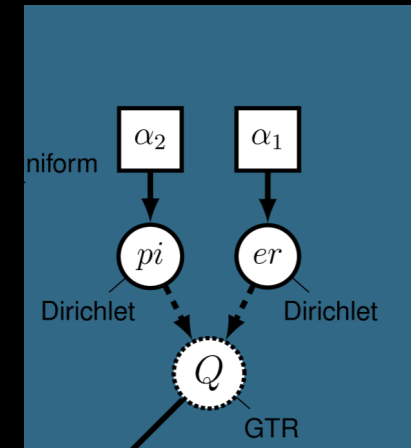
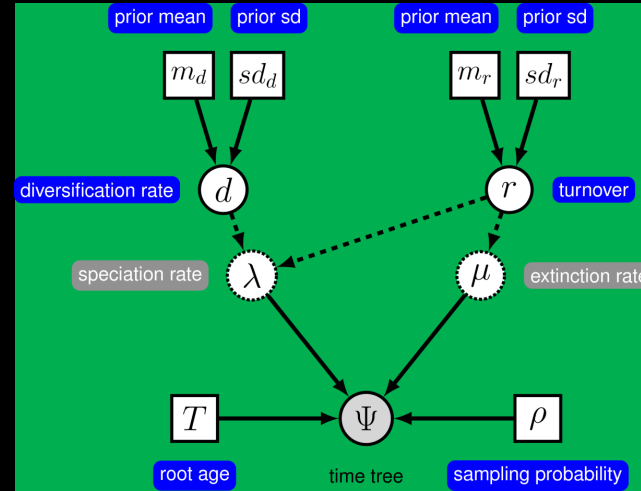
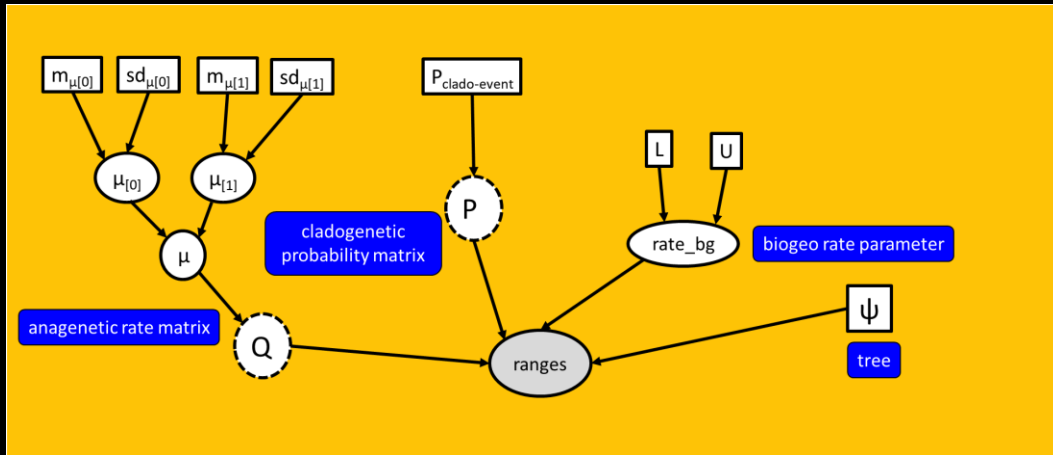

Stratigraphic Dating

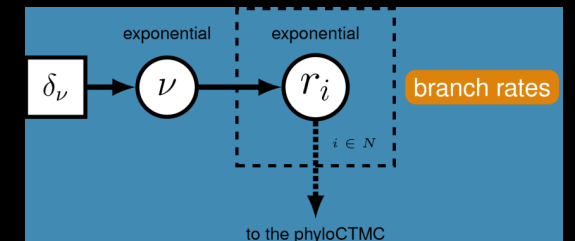
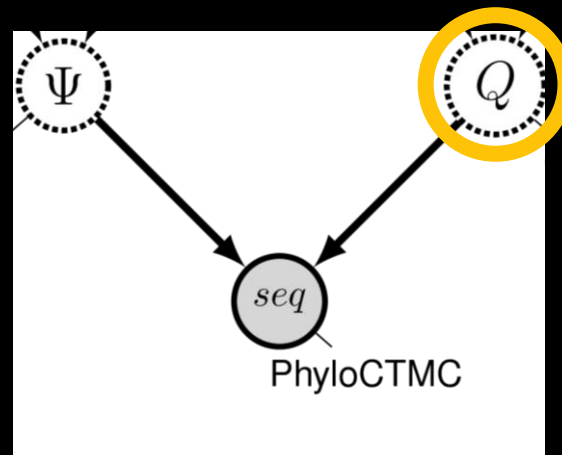
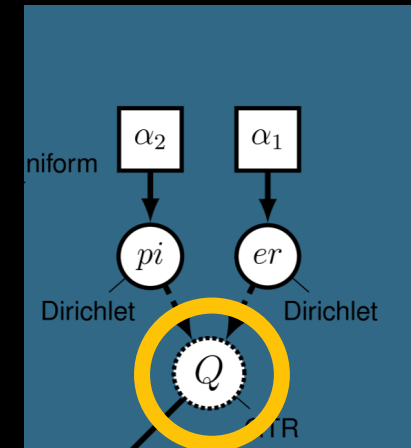
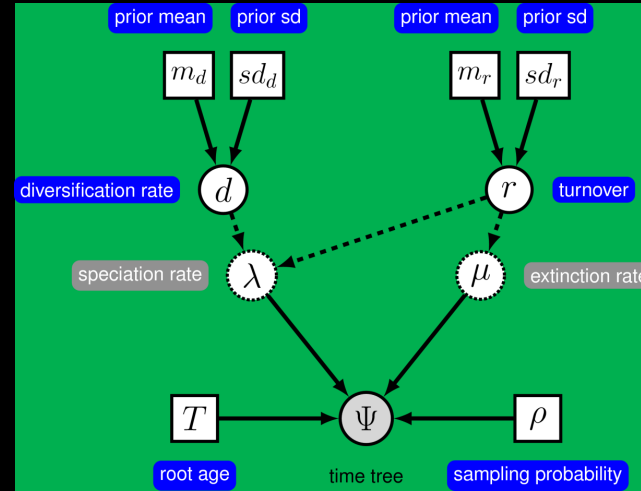
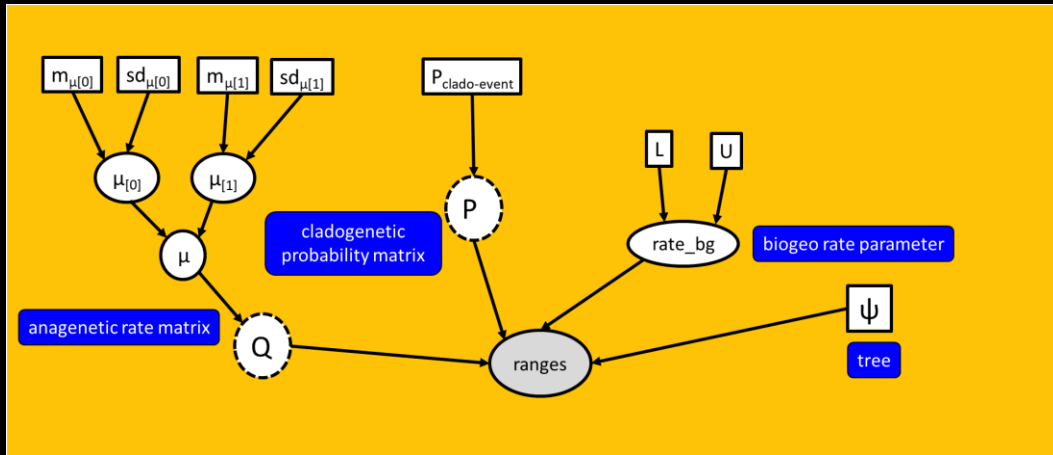

Stratigraphic Dating

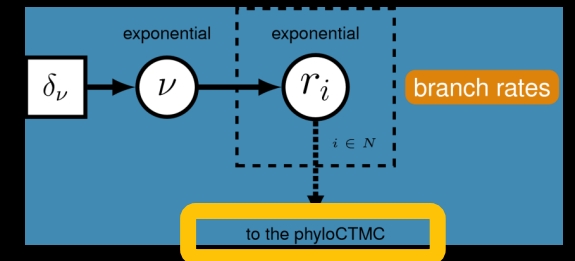
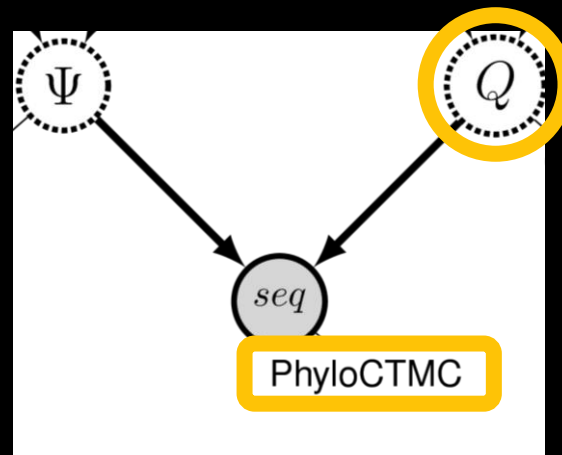
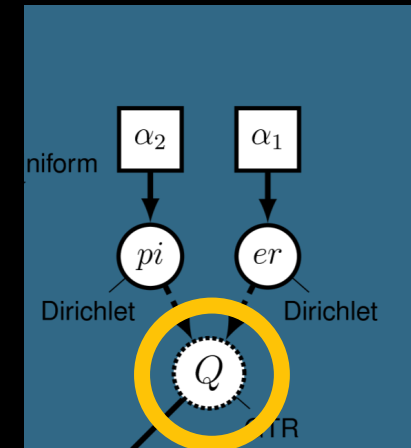
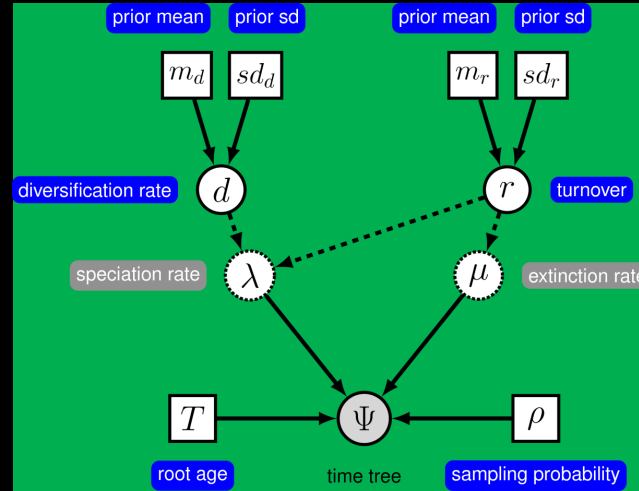
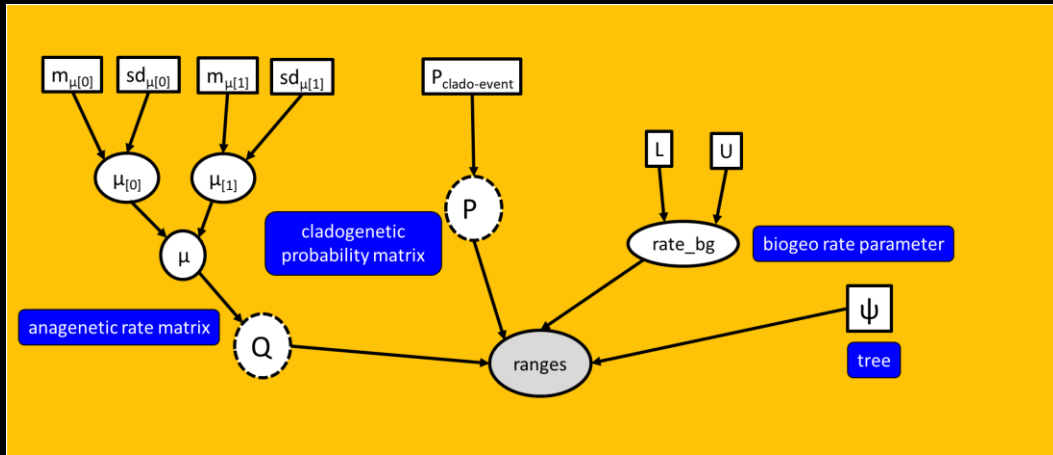

Stratigraphic Dating

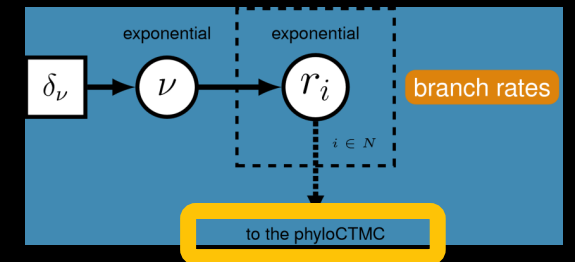
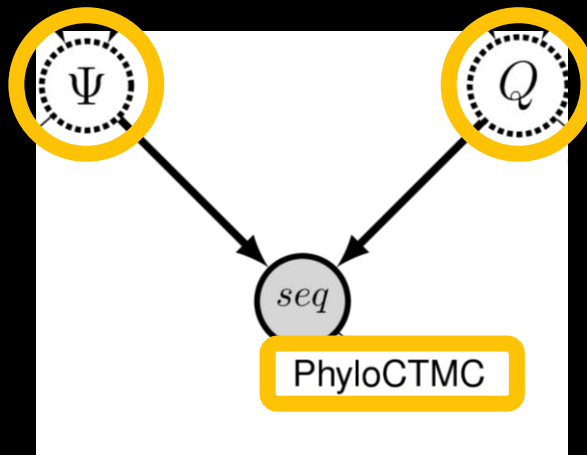
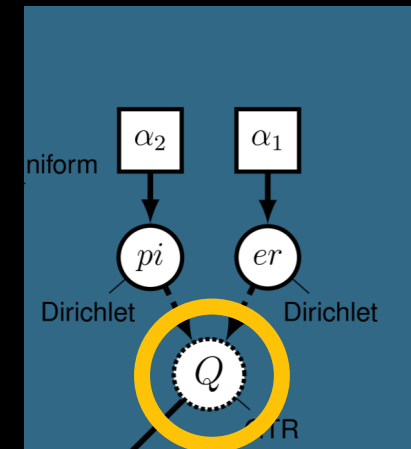
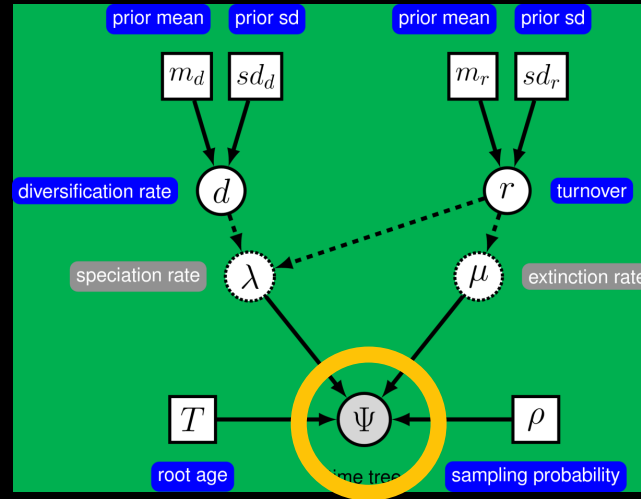
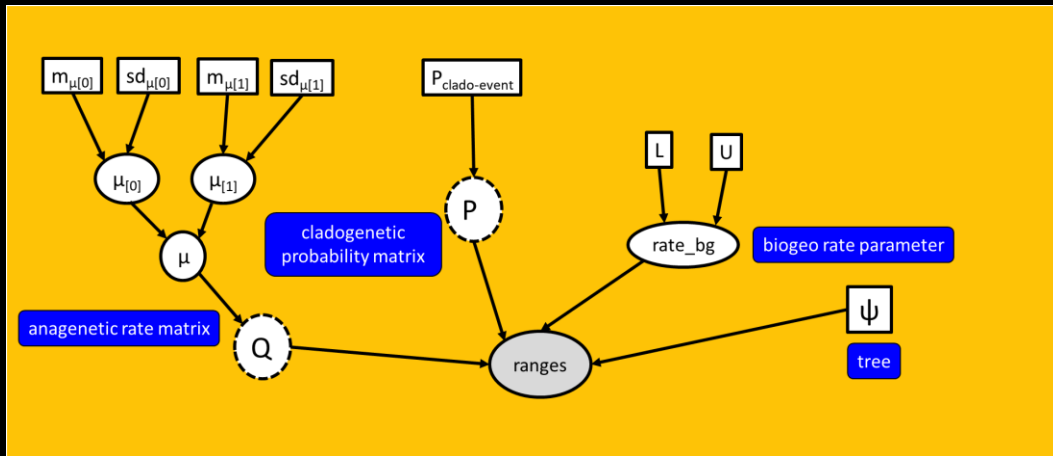

Stratigraphic Dating

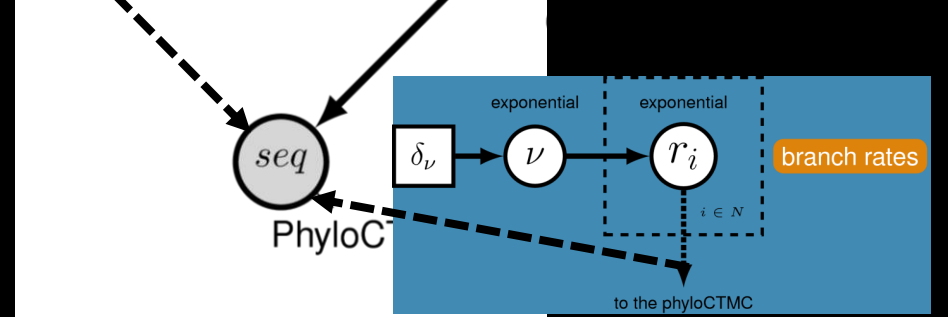
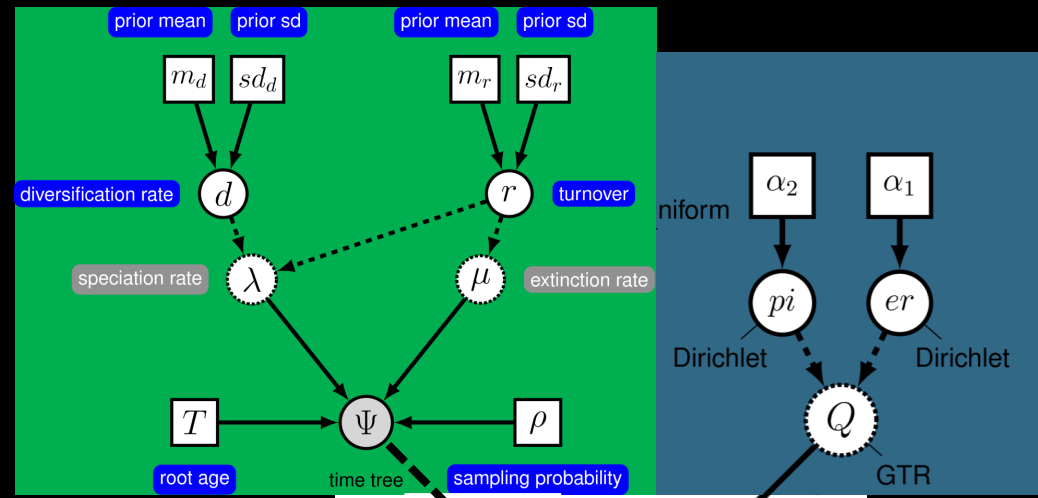
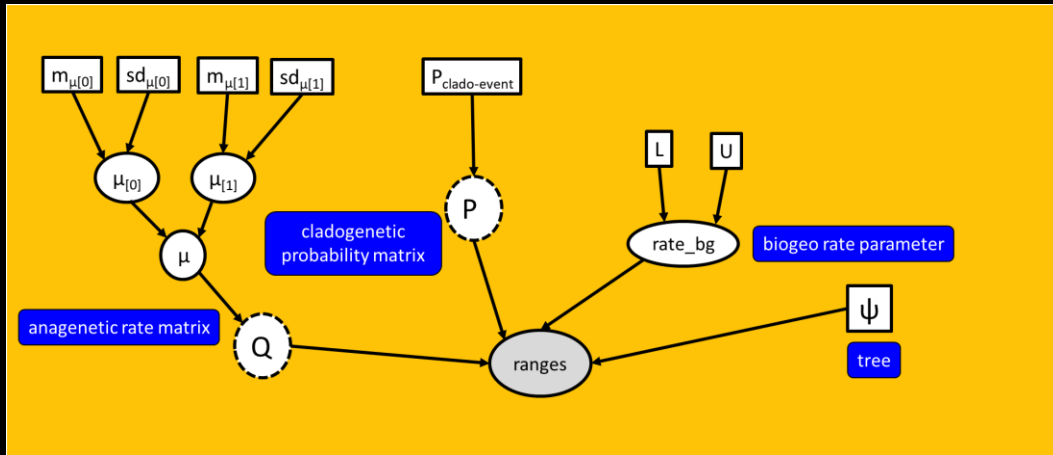

Stratigraphic Dating

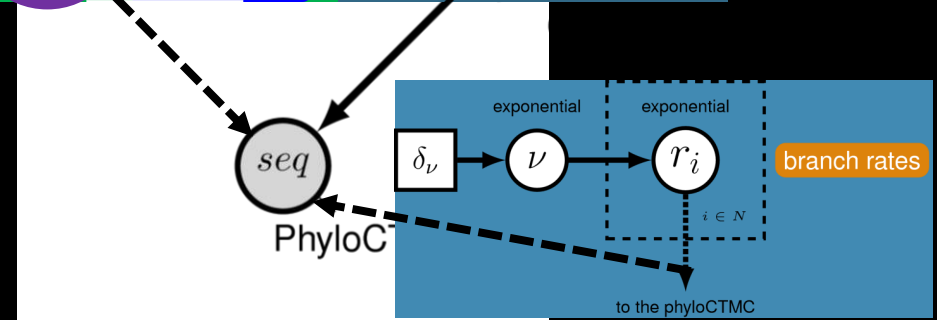
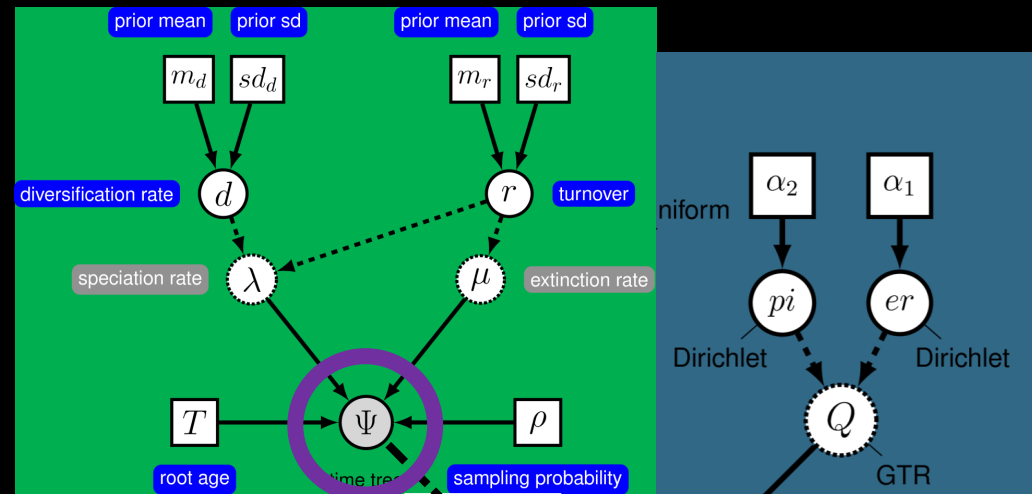
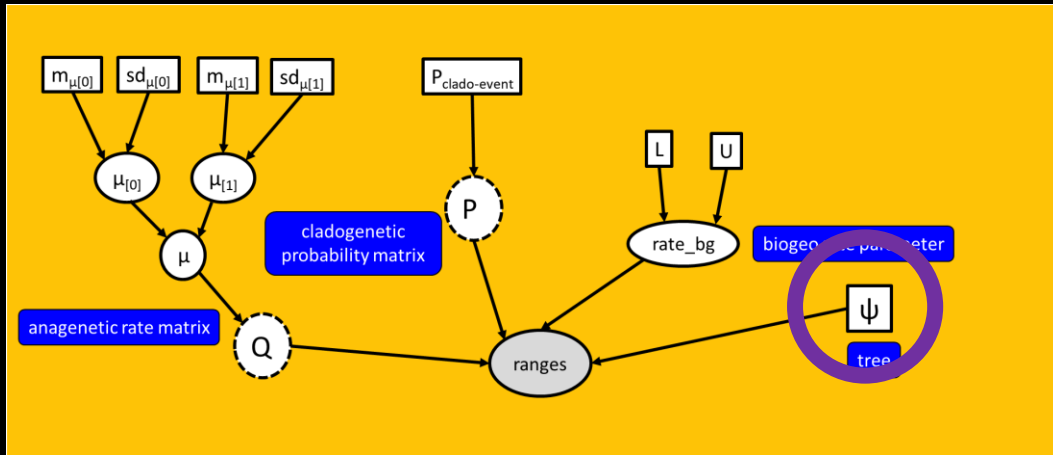

Stratigraphic Dating

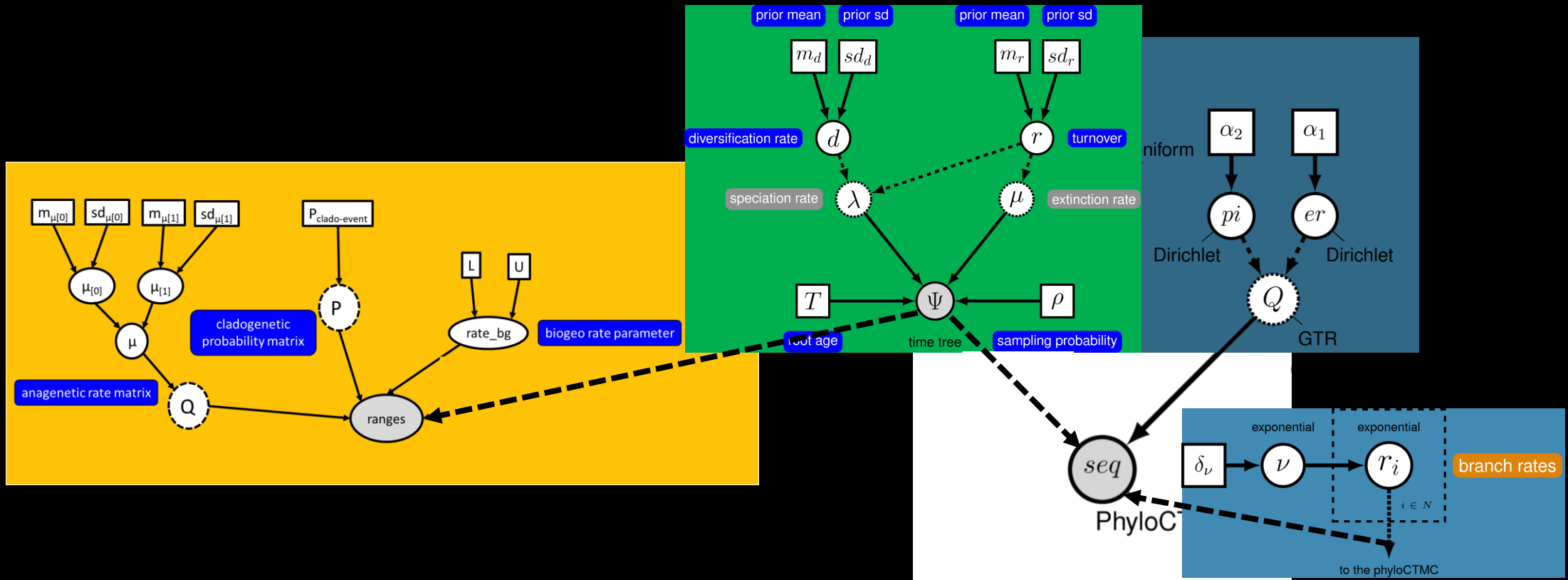

Stratigraphic Dating

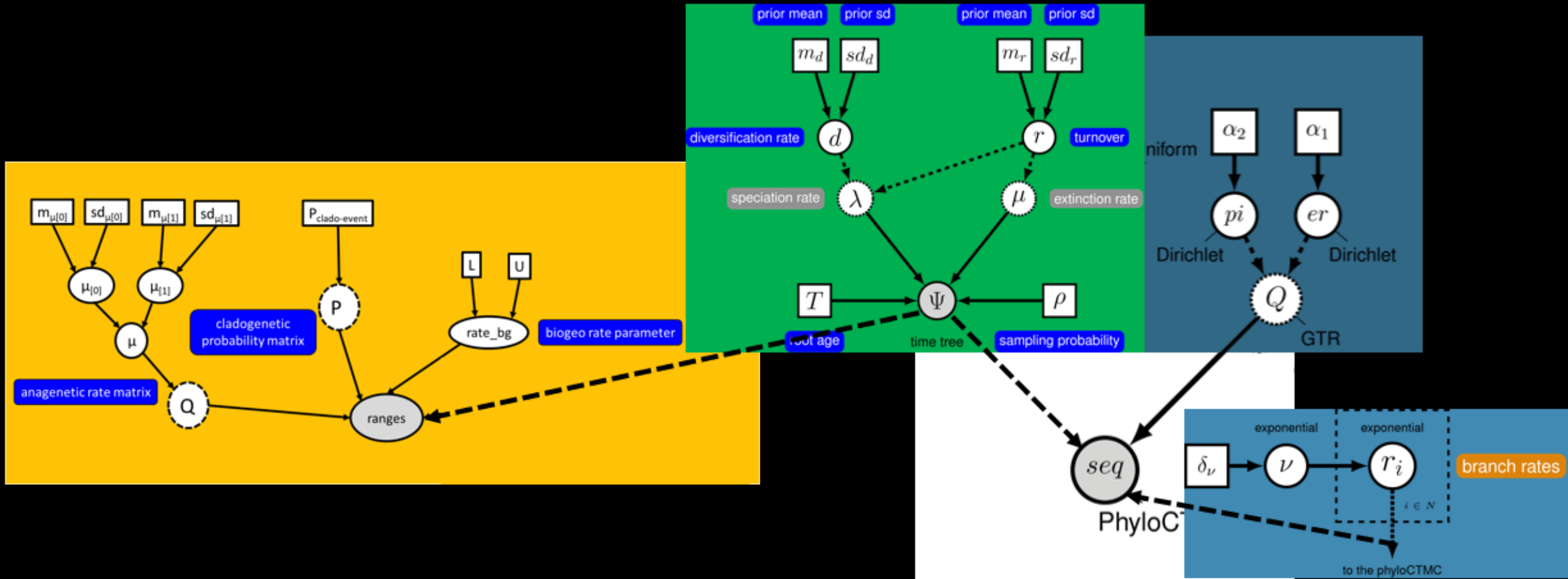

Disclaimer & the Actual People Behind This

Höhna, Landis, Heath, Boussau, Lartillot, Moore, Huelsenbeck, Ronquist. **2016**. RevBayes: Bayesian phylogenetic inference using graphical models and an interactive model-specification language. *Systematic Biology*, 65:726-736.

Höhna, Heath, Boussau, Landis, Ronquist, Huelsenbeck. **2014**. Probabilistic graphical model representation in phylogenetics. *Systematic Biology* 63:753–771.



Sebastian
Höhna



Fredrik
Ronquist



John P.
Huelsenbeck



Michael J.
Landis



Bastien
Boussau



Tracy A.
Heath



Nicolas
Lartillot



Walker
Pett



William A.
Freyman